

Double Buffer Board

Standard JFET input buffer and Standard NPN Output buffer

By PCB Guitar mania Mania

[Project link](#)

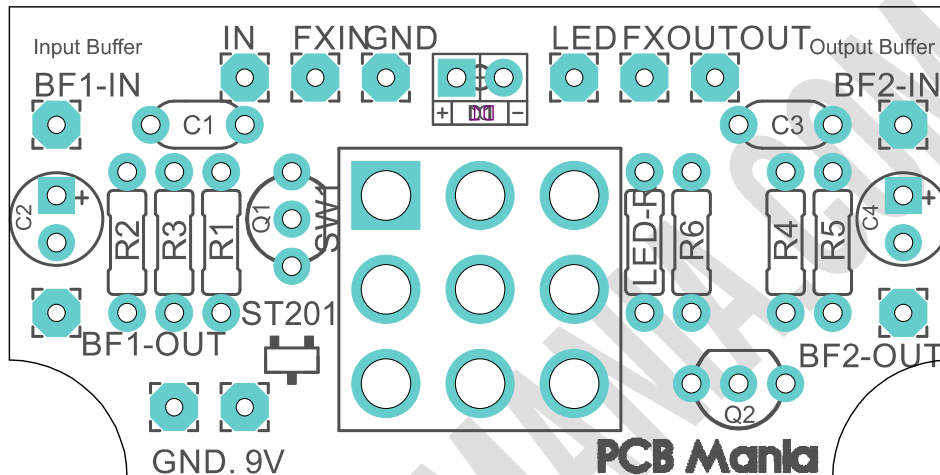

The buffers are normally added into a circuit to prevent loading and loss of definition of the guitar tone. Buffers have a high impedance to the guitar pickup and have a low impedance output drive with a gain close to unity (unity gain = 1). This is an excellent addition in front of a vintage circuit that can rob the signal of high frequency response, as well as high gain units that normally tend to self-oscillate due the pickup impedance.

- Versatile board, allows you to work in front of any effect, or as a standalone unit to control your whole setup.
- 3PDT on-board
- SMD pads for the J201.
- Tight design to fit in a 125B Enclosure

BOM

Resistors		Capacitors	
R1	1m	C1	100nf
R2	3k3	C2	10uf electro
R3	1m	C3	100nf
R4	220k	C4	10uf electro
R5	3k3		
R6	220k	Diode	
LED-R	2k7-4k7	D1	3mm Led

Transistors	
Q1*	J201*
Q2	2N5088

Q1* This Board has been designed to work with the standard T0-92 Through-hole J201 transistor, or the SMD version. Choose **only ONE**.

We always recommend to use SMD transistors, because this are more consistant on their quality, as well as cheaper and easier to find.

Shopping list

Resistors		Capacitors			
1	4k7	LED-R	2	100nf	C1, C3
2	1m	R1, R3	2	10uf	C2, C4
2	220k	R4, R6			
2	3k3	R2, R5	Led		
			1	3mm	D1

Transistors		
1	J201	Q1
1	2N5088	Q2

About the Buffers

The buffers are normally added into a circuit to prevent loading and loss of definition of the guitar tone. Buffers have a high impedance to the guitar pickup and have a low impedance output drive with a gain close to unity (unity gain = 1). This is an excellent addition in front of a vintage circuit that can rob the signal of high frequency response, as well as high gain units that normally tend to self-oscillate due the pickup impedance.

In this project we are working with a JFET Buffer for the input section and with bipolar transistor for the output section. Both of them could work at any point of the signal, but we

choose the JFET as the input buffer because of their higher input impedance and the Bipolar one for the output due their lower output impedance, as well as NPN transistors are way more available than the JFETS.

General Building notes

To populate the PCB it's recommended to follow this order.

1. Resistors & diodes
2. IC Sockets (set up the proper IC at last)
3. Capacitors, starting with the smaller ones and the ceramic ones.
4. Electrolytic capacitors (always check the polarity) In this project is recommended to **place the electrolytics on the opposite face as were is the silkscreen**, same with the **3PDT switch**, especially if you want to box it in a enclosure with some other effect.
5. Transistors
6. Wires
7. Potentiometers
8. Off board wiring

Off Board Wiring

This Board could be wired in many different ways, here bellow we listed what we consider are the most usefull.

Feel free to experiment with them as much as you want in order to dial your optimal setup.

Buffered effect

This option allows you to place the buffer after your bypass switch, and before the effect board. This pretty useful to work with the impedance of High gain units and avoid self oscillation.

- IN: To the audio Jack input
- Fx IN: To BF1-IN
- BF1-OUT: to the Input of the effect.
- Effect output: to BF2-IN
- BF2-OUT: to FX Out
- OUT: To jack output
- 9v: to the DC jack
- GND: To any of the common grounds of the project.
- D1 and LED pad: If the build has its own LED on board, avoid D1 and connect the LED CTRL pad of the effect to the LED pad on the Buffer Board.
If the Board doesn't have a led on board, you could place a standard 3mm or 5mm LED on D1 and leave the LED pad unwired.

How this works?

The 3PDT Footswitch is controlling the status of the master effect with the 2 buffers placed after the bypass switch, allowing us to choose in between our standard true by pass signal, and the buffered effect.

Mode 1, Effect On

Audio jack Input >>> Input Buffer >>> Main Effect >>> Output Buffer >>> Audio Jack Output

Mode 2, Bypass

Audio jack Input >>> Audio Jack Output

Buffer always on

If you want to wire the buffer to have it permanently activated proceed in the following way. This is pretty useful to work with the impedance of High gain units and avoid self oscillation. Bear in mind that with the buffer always on it will affect the rest of the pedal chain.

- BF1-IN: To the audio Jack input
- BF1-OUT: TO IN
- Fx IN: To the effect input.
- Fx Out: To the effect output
- Out: to BF2-IN
- BF2-OUT: to the output Jack
- 9v: to the DC jack
- GND: To any of the common grounds of the project.
- D1 and LED pad: If the build has its own LED on board, avoid D1 and connect the LED CTRL pad of the effect to the LED pad on the Buffer Board.
If the Board doesn't have a led on board, you could place a standard 3mm or 5mm LED on D1 and leave the LED pad unwired.

How this works?

The 3PDT Footswitch is controlling the status of the master effect, ON/BYPASS, but before on our signal chain we have both buffers connected, so the signal flows like in the diagram below:

Mode 1, Effect On

Audio jack Input >>> Input Buffer >>> Main Effect >>> Output Buffer >>> Audio Jack Output

Mode 2, Bypass

Audio jack Input >>> Input Buffer >>> Output Buffer >>> Audio Jack Output

Standalone Buffer

This board is also able to work as a stand alone unit, you can use both buffers independently to place them at the beginning and at the end of your pedal chain, with the possibility of switching on and off with the footswitch.

- IN: To the audio Jack input
- Fx IN: To BF1-IN.
- BF1-OUT: to a new Audio jack (We will call it Send)
- BF2-IN: To another extra audio jack (Return)
- BF2-OUT: to Fx Out
- OUT: to the output Audio Jack
- 9v: to the DC jack
- GND: To any of the common grounds of the project.
- D1, place a 3mm LED here to use it as a status indicator for the buffer.

How this works?

The standalone Buffer is a great additive on our pedalboards to help with the tone loss across the pedal chain, and as well as to control the impedance.

Mode 1, Buffer On

Guitar >>> Input Buffer >>> Pedal Chain >>> Output Buffer >>> Amplifier

Mode 2, Bypass

Guitar >>> Amplifier

Additional notes

This small board is very versatile, and it could be wired in many other ways beside the ones explained here. For example you could use just one of both buffers in certain projects. Play along with many overdrives, there are plenty of cases that are based on the classic TS808 but without the buffers, same case with DS1 based pedals. Feel free to experiment with this boards just as standalone buffer on your signal chain or try it out how it works with different classic drives.

Drilling the enclosure

This Project has been planned to fit into a 125B enclosure type (122x67x35mm approx.) along with a master effect.

It could fit as a standalone as well on a 125B, bare in mind, that the standalone version works with 4 jacks.

Check the Attached "Drilling templates" to drill the box properly. The files are on Scale 1:1, ready to print in a A4 page.

Schematic

In the JFET INPUT BUFFER the input impedance is the value of R1 (1M) paralleled by R3 (1M), or 500k ohms in this example, but It could be easily increased to 1M for more for a cleaner sound with high impedance signal sources such as high-output humbuckers or piezo sensors, Increasing the values of R1 and R3 to 2M, having an input impedance of 1M. This might produce as well a slightly increased noise due the higher value of R1. }

We recommend sticking first to the values presented here and then experiment with different values to achieve the results that fits better to your needs.

