

Cataline's Secret MKIII

Based on:

Catalinebred's Dirty little secret Mk3

Effect type:

Classic British overdrive

Build difficult:

Medium

Amount of parts:

Average, total 86 components

Technology:

JFET J201 cascade

Power consumption:

5mA (9v) / 10mA (18v)

Enclosure type:

125B

Get your board at:

[Cataline's Secret MKIII](#)

Get your kit at:

[Das Musikding \(Europe\)](#)

Project overview:

Classic British sound and responsiveness of the classic Plexi to Super Lead and Super Bass of the early 70s, two classic circuits that can be selected via an internal slide switch. Works very well as an "always on" pedal as the core of the guitar sound, which can be extended by the upstream of boosters, fuzzes, filters and other overdrives

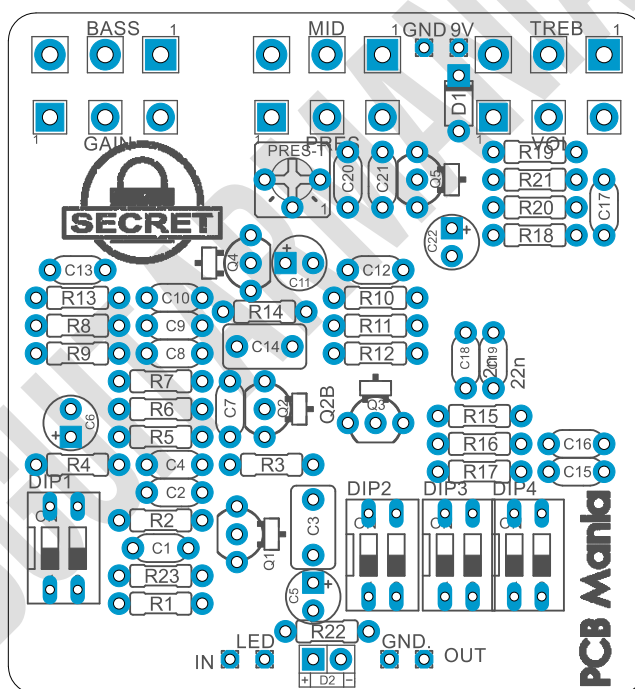

Real measures are:

58mm width x 62mm height

2.28" width x 2.44" height

Index

1. Project overview
2. Index, Introduction & Controls
3. Bills of Materials, BOM
4. Shopping Lists
5. Components Recommendations
6. Build Notes
7. Schematic
8. Wiring Diagram
9. Drill Template
10. Licensing and Usage

Introduction

The Cataline's Secret MKIII is based on the Catalinebred's Dirty little secret MKIII, featuring two distinct voicings - "Super Lead" and "Super Bass" switchable via an internal set of DIP switches or by an external 4PDT. Thanks to the DIP switches, you can dial your settings individually, combining the best of each voices at taste.

Including the option to choose in between an internal trimmer to control the presence, or to solder an external 16mm standard pot.

Designed to perform the best at 18v, always ensure to be using capacitors rated for V25 or more.

This project works based on JFET J201, biased by common resistors instead of trim pots, making easier for the builder to have this project sounding. Also features pads to use standard through hole J201 or the more available and reliable SMD version.

Controls

The Cataline's Secret MKIII has the same external controls as most overdrive or distortion effects, including a 3 tone controls.

- Gain: This controls the gain or amount of overdrive.
- Volume: This knob controls the output volume.
- Presence: allows you to fine-tune the amount of presence or high treble frequencies that the pedal produces.
- Treble: Circuit-wise, it is actually a sort of "mixer" control, mixing between the treble side and the middle/bass side. So if you want a less bassy sound, not only would you turn the Bass control down but you might also want to turn the Treble control up to "mix" less of the middle/bass frequencies into the sound.
- Middle: It can also be thought of as a sort of "gain" knob since most of the guitar's energy is in the middle frequencies. So if you want the gainiest sound possible, run the Middle knob high. But if you wanna less gainy sound run it lower. Which means you might also want to run the Treble and Bass knobs even lower to balance things out.
- Bass: Loyal to the Marshall sound, it delivers a lot of bass! So don't feel like you're doing something wrong if you like to run the Bass control at a very low setting.

Bill of materials

Resistors	
R1	470K
R2	33k
R3	820r
R4	1m
R5	1K
R6	1M
R7	1M
R8	470k
R9	47k
R10	1K
R11	1M
R12	1M
R13	470k
R14	560r
R15	100k
R16	56k
R17	33k
R18	1k
R19	2m2
R20	2m2
R21	4k7
R22	2k7-4k7
R23	1M

Capacitors	
C1	220n
C2	1n
C3	680n
C4	2n2
C5	22uf electrolytic
C6	2.2uf electrolytic
C7	220p
C8	22n
C9	47p
C10	470p
C11	2.2uf electrolytic
C12	470p
C13	470p
C14	680n
C15	270p
C16	470p
C17	22n
C18	22n
C19	22n
C20	220n
C21	100n
C22	47uf electrolytic

Potentiometers	
TREB	250K B
VOL	250K B
BASS	1M A
GAIN	1M A
MID	25K B
PRES	10K B*

Semiconductors	
Q1	J201
Q2	J201
Q3	J201
Q4	J201
Q5	J201
D1	1n4001
D2	3mm red led***

Switches**	
DIP1	Two poles DIP switch
DIP2	Two poles DIP switch
DIP3	Two poles DIP switch
DIP4	Two poles DIP switch

Pres* Remember you can choose either for a 10k trim pot, just like in the original version, or for a 10k B potentiometer for external control.

Switches** Same as with Pres control, choose in between 4 dip switches as in the original version, or for a 4pdt toggle for external control. These switches are in charge of selecting in between the Super Bass mode and the Super Lead mode.

D2*** On all projects we feature the Status led (on/off) on board. Feel free to choose either color and dimension you like the most.

Shopping list

Resistors

Qty	Value	Parts
1	2K7-4K7	R22
1	4k7	R21
1	560r	R14
1	56k	R16
1	820r	R3
2	33k	R2, R17
1	470K	R1
2	470k	R8, R13
2	2m2	R19, R20
1	100k	R15
1	47k	R9
3	1K	R5, R10, R18
6	1M	R4, R6, R7, R11, R12, R23

Potentiometers

Qty	Value	Parts
2	250K B	VOL, TREB
1	10K B	PRES
1	25K B	MID
2	1M A	GAIN, BASS

Switches

Qty	Value	Parts
4	Dip 2 pole	DIP1, DIP2, DIP3, DIP4
1	4PDT	External toggle mod

Capacitors

Qty	Value	Parts
1	100n	C21
1	1n	C2
2	2.2uf	C6, C11
2	220n	C1, C20
1	220p	C7
2	22n	C8, C17, C18, C19
1	22uf	C5
1	270p	C15
1	2n2	C4
4	470p	C10, C12, C13, C16
1	47p	C9
1	47u	C22
2	680n	C3, C14

Semi conductors

Qty	Value	Parts
5	J201	Q1, Q2, Q3, Q4, Q5
1	3mm led	D2
1	1n4001	D1

Components Recommendations

For this project is a must to use **JFET J201*** from a trusted source such as Das Musikding, Small bear, and many other pedal related suppliers. DO NOT trust non verified vendors, as are many counterfeits out there, and they won't work properly on your build.

This board features the possibility of use the SMD (Surface mounted device) J201, as well as the classic format TO-92 (regular transistor) now discontinued; place either the SMD version or the standard one per transistor position.

As many people like to experiment some pedals with higher voltage, always ensure the max tolerance of your **electrolytic capacitors** is over 25v.

This board has been tested using Film box capacitors for most of the values over 1nf, and ceramics discs for the ones under 1nf. However, high quality components such as Wima's Capacitors and Panasonic's electrolytics can deliver a better performance.

All the resistors used for testing this project are 1/4W Metal Film.

All the pots are Alpha 16mm.

The BOM and Shopping list are exclusively regarding this project. It doesn't include all the hardware like the 3PDT bypass switch, audio/dc jacks, enclosure, etc.

The **4 DIP SWITCHES** could be replaced by the external **4PDT** toggle mod to switch in between the Super Bass mode and the Super Lead Mode. Check the wiring section for more information.

Build Notes

If this is one of your first projects I recommend you to take a look on our [Pedal Building Guide](#)

For a successful and tidy build it's recommended the following order:

1. SMD Transistors
2. Resistors & diodes
3. Capacitors, starting with the smaller ones and the ceramic ones.
4. Electrolytic capacitors (always check the polarity)
5. Transistors
6. Wires
7. Potentiometers and switches
8. Off board wiring
9. Transistor bias

Wiring Diagram

All our projects include a free 3PDT Board to make the wiring easier and tidier. Also all of our PCBs feature the status LED on board.

The pad named “Ctrl” or “LED” is the one that controls the status of the led, wire it to the “LED”pad on the 3PDT board, or in control slug of your 3PDT.

You can take a look on the following diagram to understand the general connections. For further information check our [Pedal Wiring guide](#).

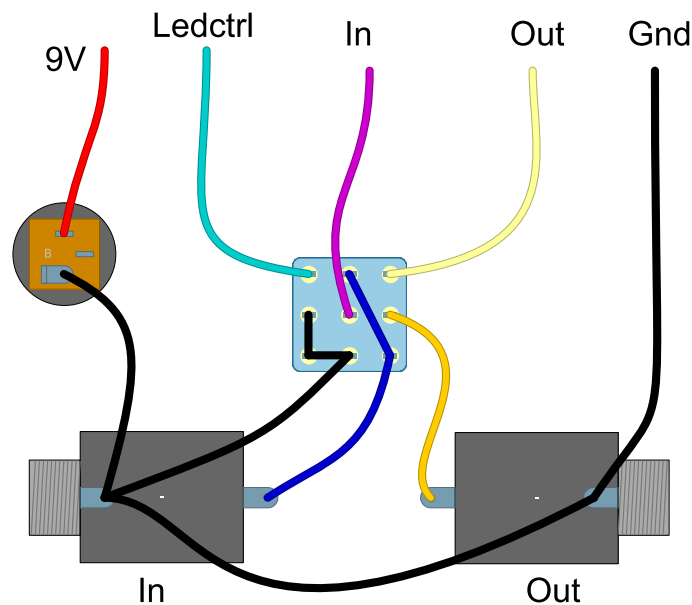

4PDT toggle mod

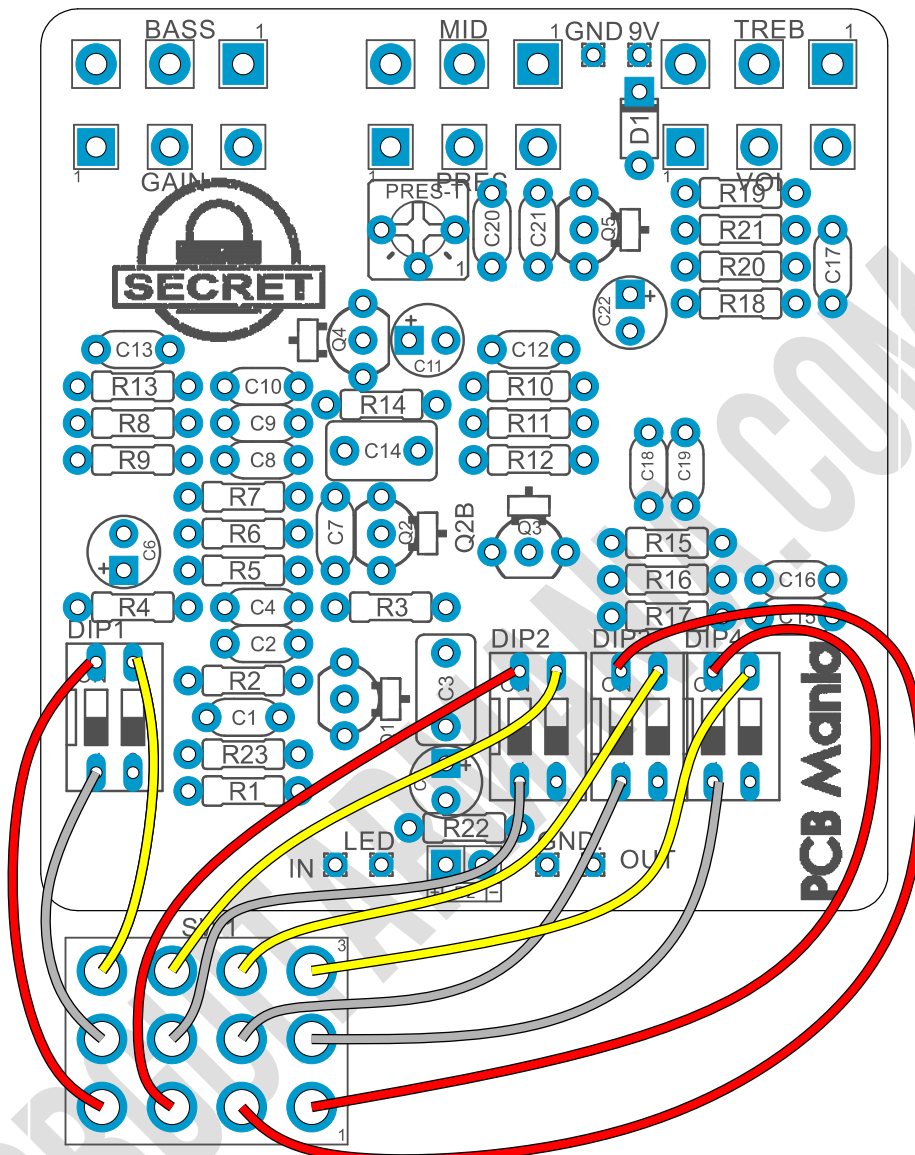

Drill Template

This Project has been planned to fit into a 125B enclosure type (122x67x35mm approx.)

Check the Attached "Drilling templates" to drill the box properly. The files are on Scale 1:1, ready to print in a A4 page.

Licensing and Usage

We really appreciate your trust and support buying this PCB, as well as your will to dive into the DIY electronics world. That's why for us is really important that you can make this project work properly and to enjoy not only the building process, but also to experiment and play with it on your rig.

We try to reply to every question we receive on our email or in our social media, but we try to encourage all our customers to join our [PCB Guitar Mania – Builders Grup](#) on Facebook, in order to post all your doubts, issues, suggestions or request, as well to share your builds and have some feedback from us and other fellow builders!

All of our projects have been tested following this same guide on their standard configurations. Although, not all of the variations and mods have necessarily been tested. These are suggestions based on the schematic analysis, and on the experiences and opinions of others. Feel free to share with us your opinions and suggestions regarding the mods our your own personal experimentation.

These boards may be used for commercial endeavors in any quantity unless specifically noted. No attribution is necessary, though accreditation or a link back is always greatly appreciated.

If you are a builder planning to make your own run of pedals we also offer the service of custom made boards with your brand and logo, design according your specifications.

The only usage restrictions are that, first, you cannot resell the PCB as part of a kit without prior arrangement with us, and second, you cannot scratch off the silk screen, or other way of trying to hide our logos and the source of the PCBs. Like its written above, if you want to have your own designs, with your brand and logo we could certainly reach an agreement.

Follow us on [Instagram](#) and [Facebook](#) to stay in tune with the latest projects!