

# Crysis

**Based on:**

Suhr Riot

**Effect type:**

Distortion

**Build difficult:**

Average

**Amount of parts:**

Low, total 45 components

**Technology:**

Double dual Op-Amp

**Power consumption:**

8mA (9v-18v)

**Enclosure type:**

1590bb

**Get your board at:**

[Crysis](#)

**Get your kit at:**

[Das Musikding \(Europe\)](#)

**Project overview:**

Crysis is a versatile high-gain distortion pedal with the sonic characteristics and touch sensitivity of a high quality 100 watt tube amplifier.

Especially good for tight crunch rhythms and dynamic solos.

This board features an internal Presence trimmer.

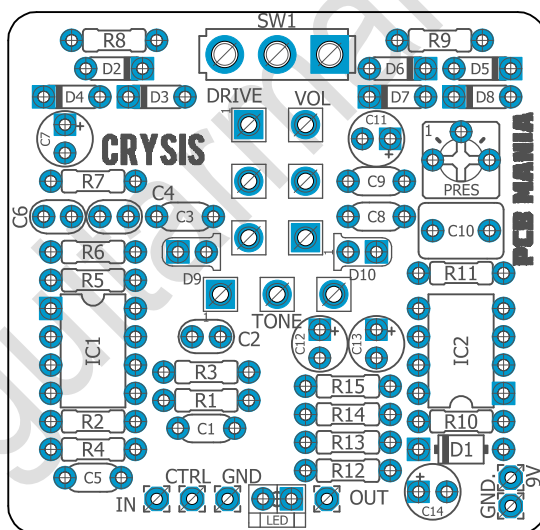

# Index

---

- |                                   |                         |
|-----------------------------------|-------------------------|
| 1. Project overview               | 6. Build Notes          |
| 2. Index, Introduction & Controls | 7. Schematic            |
| 3. Bills of Materials, BOM        | 8. Wiring Diagram       |
| 4. Shopping Lists                 | 9. Drill Template       |
| 5. Components Recommendations     | 10. Licensing and Usage |

## Introduction

---

The Crysis is a circuit inspired on the famous Suhr Riot, without being an exact replica, through the years they have been many different versions of the Riot and the riot Reloaded, most of them with small values changes on the components and in the clipping section. For this project I've made a research of the most common versions of this pedal and many schematics provided by the DIY community in order to lay down an ultimate boutique version of it that captures the best essence of the original Suhr Riot.

If we take a look to the schematic, we can find many similarities to the M-Audio Crunch Box, later also cloned and modded by JHS as the Angry Charlie, you can check our Angry Carlos if you want to build either of these.

The Crunch Box it also has roots on some other famous pedals as the Marshall Blues Breaker and the Fulltone OCD. So we can proudly say that PCB Guitar Mania's Crysis is the prodigal son of a long family of Marshall-like pedals, taking the best of each model through the years and refining it as one of the most lauded high-gain "stack of amps" pedal.

## Controls

---

- Drive: Adjusts the amount of gain added to your tone, taking you from classic crunch to high-gain heaven.
- Vol: Adjusts the output of the pedal. Riot provides enough level to push the front end of any tube amp into natural overdrive.
- Tone: Shapes the overall tonal response of the pedal, from smooth and warm to cutting lead tones.
- Presence: affects the overall 'shape' of the tone of the pedal. It interacts with the tone control.
- Diode Switch: Select In between 3 Different clipping options. To the left engages the symmetrical Germanium diodes + the LED pair, to the right the asymmetrical Silicon diodes + Led pair, on the center we got just the Pair of LEDs, being the loudest of all the 3 options, with more open and organic tone. The pair of LEDs clip are hardwired as always on.

# Bill of materials

---

Resistors	
Part	Value
R1	2m2
R2	1m
R3	1k
R4	1k
R5	10k
R6	1m
R7	470r
R8	220r
R9	470r
R10	100k
R11	100r
R12	4k7
R13	100r
R14	22k
R15	22k

Capacitors	
Part	Value
C1	22n
C2	33pf
C3	100n
C4	100pf
C5	220n
C6	100pf
C7	2u2
C8	22n
C9	22n
C10	1uf
C11	10u
C12	10u
C13	10u
C14	100u

Diodes	
Part	Value
D1	1n4001
D2	1n914*
D3	1n914
D4	1n914
D5	1n34a
D6	1n34a
D7	1n34a
D8	1n34a
D9	3mm Red Led
D10	3mm Red Led
LED	3mm LED

IC	
Part	Value
IC1	JRC4580
IC2	JRC4580

Potentiometers	
Part	Value
DRIVE	100K B
TONE	10K C
VOL	10K A
PRES	20k

Switches	
Part	Value
SW1	SPDT ON-OFF-ON

# Shopping list

---

Resistors		
Qty	Value	Parts
1	2m2	R1
1	100k	R10
2	100r	R11, R13
1	4k7	R12
2	22k	R14, R15
2	1m	R2, R6
2	1k	R3, R4
1	10k	R5
2	470r	R7, R9
1	220r	R8

Capacitors		
Qty	Value	Parts
3	22n	C1, C8, C9
1	1uf	C10
3	10u	C11, C12, C13
1	100u	C14
1	33pf	C2
1	100n	C3
2	100pf	C4, C6
1	220n	C5
1	2u2	C7

Diodes		
Qty	Value	Parts
1	1n4001	D1
3	1n914	D2, D3, D4
4	1n34a	D5, D6, D7, D8
3	3mm Red LED	D9, D10, LED

Potentiometers		
Qty	Value	Parts
1	10K C	TONE
1	10K A	VOL
1	100K B	DRIVE
1	20k	PRES

IC		
Qty	Value	Parts
2	JRC4580	IC1, IC2

Switch		
Qty	Value	Parts
1	SPDT ON-OFF-ON	SW1

# Components Recommendations

---

As many people like to experiment some pedals with higher voltage, always ensure the max tolerance of your **electrolytic capacitors** is over 25v.

This board has been tested using Film box capacitors for most of the values over 1nf, and ceramics discs for the ones under 1nf. However, high quality components such as Wima's Capacitors and Panasonic's electrolytics can deliver a better performance.

All the resistors used for testing this project are 1/4W Metal Film.

The BOM and Shopping list are exclusively regarding this project. It doesn't include all the hardware like the 3PDT bypass switch, audio/dc jacks, enclosure, etc.

**D2\* in many schematics online D2 is actually a BLUE 3mm LED. Feel free to socket and experiment with it and tell us which one you like the most.**

## Build Notes

---

If this is one of your first projects I recommend you to take a look on our [Pedal Building Guide](#)

For a successful and tidy build it's recommended the following order:

1. Resistors & diodes
2. Capacitors, starting with the smaller ones and the ceramic ones.
3. Electrolytic capacitors (always check the polarity)
4. Transistors
5. Wires
6. Potentiometers and switches
7. Off board wiring

# Schematic

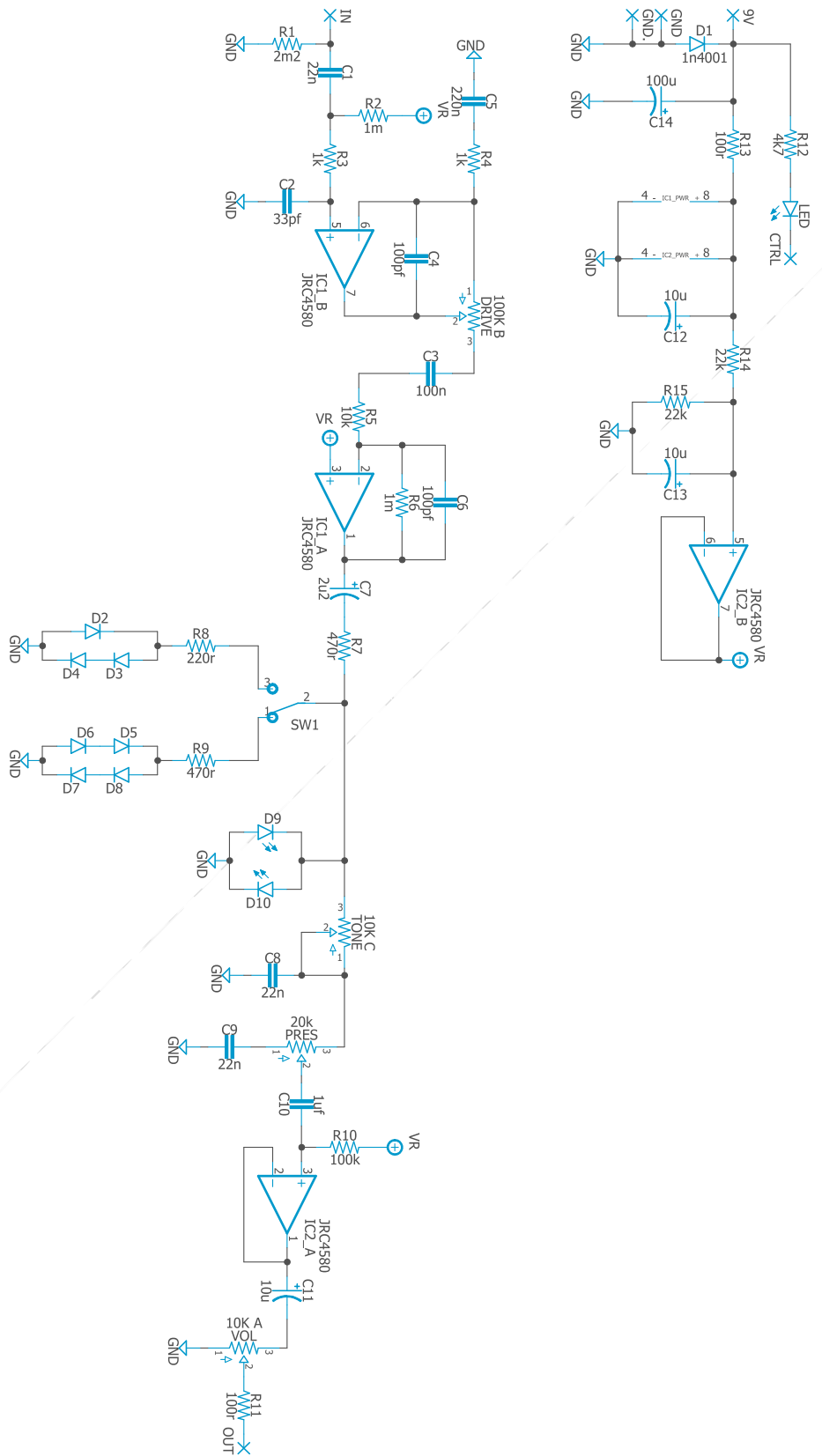

# Wiring Diagram

All our projects include a free 3PDT Board to make the wiring easier and tidier. Also all of our PCBs feature the status LED on board.

The pad named “Ctrl” or “LED” is the one that controls the status of the led, wire it to the “LED” pad on the 3PDT board, or in control slug of your 3PDT.

You can take a look on the following diagram to understand the general connections. For further information check our [Pedal Wiring guide](#).

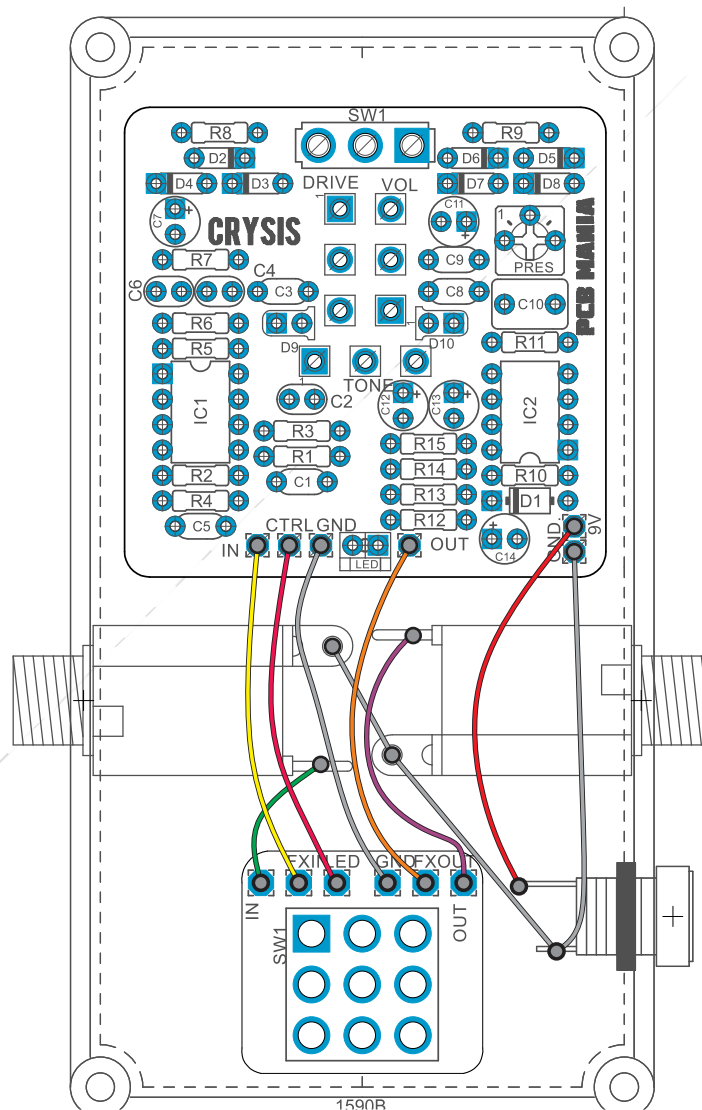

# Drill Template

---

This Project has been planned to fit into a 1590B enclosure type (122x67x35mm approx.)

Check the Attached “Drilling templates” to drill the box properly. The files are on Scale 1:1, ready to print in an A4 page.

## Licensing and Usage

---

We really appreciate your trust and support buying this PCB, as well as your will to dive into the DIY electronics world. That’s why for us is really important that you can make this project work properly and to enjoy not only the building process, but also to experiment and play with it on your rig.

We try to reply to every question we receive on our email or in our social media, but we try to encourage all our customers to join our [PCB Guitar Mania – Builders Group](#) on Facebook, in order to post all your doubts, issues, suggestions or request, as well to share your builds and have some feedback from us and other fellow builders!

All of our projects have been tested following this same guide on their standard configurations. Although not all of the variations and mods have necessarily been tested. These are suggestions based on the schematic analysis, and on the experiences and opinions of others. Feel free to share with us your opinions and suggestions regarding the mods your own personal experimentation.

These boards may be used for commercial endeavors in any quantity unless specifically noted. No attribution is necessary, though accreditation or a link back is always greatly appreciated.

If you are a builder planning to make your own run of pedals, we also offer the service of custom made boards with your brand and logo, design according your specifications.

The only usage restrictions are that, first, you cannot resell the PCB as part of a kit without prior arrangement with us, and second, you cannot scratch off the silk screen, or other way of trying to hide our logos and the source of the PCBs. Like it’s written above, if you want to have your own designs, with your brand and logo we could certainly reach an agreement.

Follow us on [Instagram](#) and [Facebook](#) to stay in tune with the latest projects!