

King-Kat

Based on:

Catalinebread's Katzenkönig

Effect type:

Fuzz-distortion

Build difficult:

Average

Amount of parts:

Average, total 45 components

Technology:

Silicon Tone Bender into Rat clipping and filter section

Power consumption:

23mA (9v)

Enclosure type:

1590b

Get your board at:

[King-Kat](#)

Get your kit at:

[Das Musikding \(Europe\)](#)

Project overview:

The King-kat combines the best elements of a Tone Bender MkII fuzz with a Rat distortion to create something that sings like a fuzz but is tight like a distortion.

This board features a toggle switch to select in between two pairs of clipping diodes.

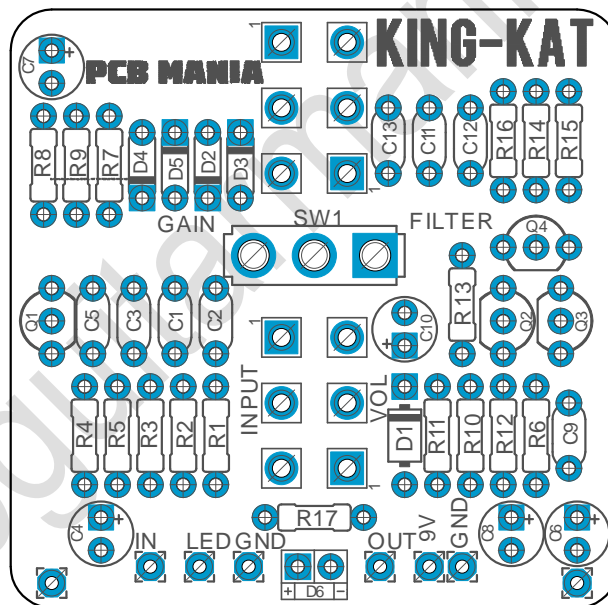

Real measures are:

46mm width x 46mm height

1.81" width x 1.81" height

Index

1. Project overview
2. Index, Introduction & Controls
3. Bills of Materials, BOM
4. Shopping Lists
5. Components Recommendations
6. Build Notes
7. Schematic
8. Wiring Diagram
9. Drill Template
10. Licensing and Usage

Introduction

The front half of the circuit is based on the Tone Bender MKII, employing silicon transistors instead of germanium ones, which can mean an even louder, nastier Bender. After the third transistor, the signal encounters the second half of a Rat circuit, which it's a pair of clipping diodes and a clever single-knob tone circuit.

On this circuit, the diodes focus the blaring, splattery MKII sound. Lows get tighter and heavier. The filter control works wonders, enabling shades you'd never obtain from a MKII. Bright settings sizzle, but not excessively so, while dark tones maintain impact

This spawn of a Tone Bender MKII and an early Rat doesn't sound like either of its forebears. Instead, it splits the difference between the two. You get fiery fuzz with uncommon tightness—or, to put it another way, tough distortion with a strong dose of explosive fuzz

Controls

- **Input:** Acts as the volume knob of the guitar to set the amount of signal input into the pedal.
- **Gain:** The Gain control differs from the original MkII to make it much more useful even at low gain settings. Instead of altering the voltage from a transistor to ground, it tweaks the resistance of a negative feedback loop between two transistors.
- **Filter:** Works as tone Control.
- **Volume:** Set the output of the circuit.
- **Diode Switch:** Choose in Between the stock diodes of the original circuit or by any other pair of your choose (3mm red LEDs, Bat46, etc.) Or even bypass the diodes with a SPDT On-Off-On toggle.

Bill of materials

Resistors	
Part	Value
R1	1m
R2	100k
R3	470k
R4	1k
R5	10k
R6	1k
R7	3k9
R8	150r
R9	1k
R10	22k
R11	3k9
R12	2k2
R13	1k
R14	1m
R15	1m
R16	3k3
R17	4k7

Capacitors	
Part	Value
C1	68n
C2	1n
C3	47pf
C4	22uf
C5	150n
C6	10uf
C7	10uf
C8	47uf
C9	10n
C10	4u7
C11	3n3
C12	220nf
C13	1uf

Potentiometers	
Part	Value
FILTER	100K A
GAIN	250K B
INPUT	250K B
VOL	100K A

Transistors*	
Part	Value
Q1	BC550B
Q2	BC550B
Q3	BC550B
Q4	BC550B

Switches	
Part	Value
SW1	SPDT ON-OFF-ON

Diodes	
Part	Value
D1	1n5817
D2	1n914
D3	1n914
D4**	your choice
D5**	your choice
D6	3mm Led

Shopping list

Resistors		
Qty	Value	Parts
3	1m	R1, R14, R15
1	150r	R8
4	1k	R4, R6, R9, R13
1	2k2	R12
1	3k3	R16
2	3k9	R7, R11
1	470k	R3
1	100k	R2
1	10k	R5
1	22k	R10
1	4k7	R17

Capacitors		
Qty	Value	Parts
1	4u7	C10
1	68n	C1
1	47pf	C3
1	47uf	C8
1	3n3	C11
1	1uf	C13
1	220nf	C12
1	10n	C9
2	10uf	C6, C7
1	150n	C5
1	1n	C2
1	22uf	C4

Diodes		
Qty	Value	Parts
1	1n5817	D1
2	1n914	D2, D3
1	3mm LED	D6
2	your choice	D4, D5

Potentiometers		
Qty	Value	Parts
2	100K A	FILTER, VOL
2	250K B	GAIN, INPUT

Transistors		
Qty	Value	Parts
4	BC550B	Q1, Q2, Q3, Q4

Switches		
Qty	Value	Parts
1	SPDT ON-OFF-ON	SW1

Components Recommendations

As many people like to experiment some pedals with higher voltage, always ensure the max tolerance of your **electrolytic capacitors** is over 25v.

This board has been tested using Film box capacitors for most of the values over 1nf, and ceramics discs for the ones under 1nf. However, high quality components such as Wima's Capacitors and Panasonic's electrolytics can deliver a better performance.

All the resistors used for testing this project are 1/4W Metal Film.

The BOM and Shopping list are exclusively regarding this project. It doesn't include all the hardware like the 3PDT bypass switch, audio/dc jacks, enclosure, etc.

The **Transistors*** on the original Katzenkönig are BC550B (In between 300-400 HFE), however I've built the first unit using the **2N3904** NPN with great results. Some sources on the DIY community have reported using other low gain NPN transistors such as the 2N2222 or even some medium gain as the 2N5088. Feel free to experiment with different transistors on different positions.

For extra pair of selectable **Diodes**** I've used Red Leds to have a bit of that feeling of driving a Tone Bender Into a Plexi, Having more headroom and less clipping that with the stock diodes. However I'd recommend you to socket and try as many diodes as you want to dial the perfect tone.

Build Notes

If this is one of your first projects I recommend you to take a look on our [Pedal Building Guide](#)

For a successful and tidy build it's recommended the following order:

1. Resistors & diodes
2. Capacitors, starting with the smaller ones and the ceramic ones.
3. Electrolytic capacitors (always check the polarity)
4. Transistors
5. Wires
6. Potentiometers and switches
7. Off board wiring

Schematic

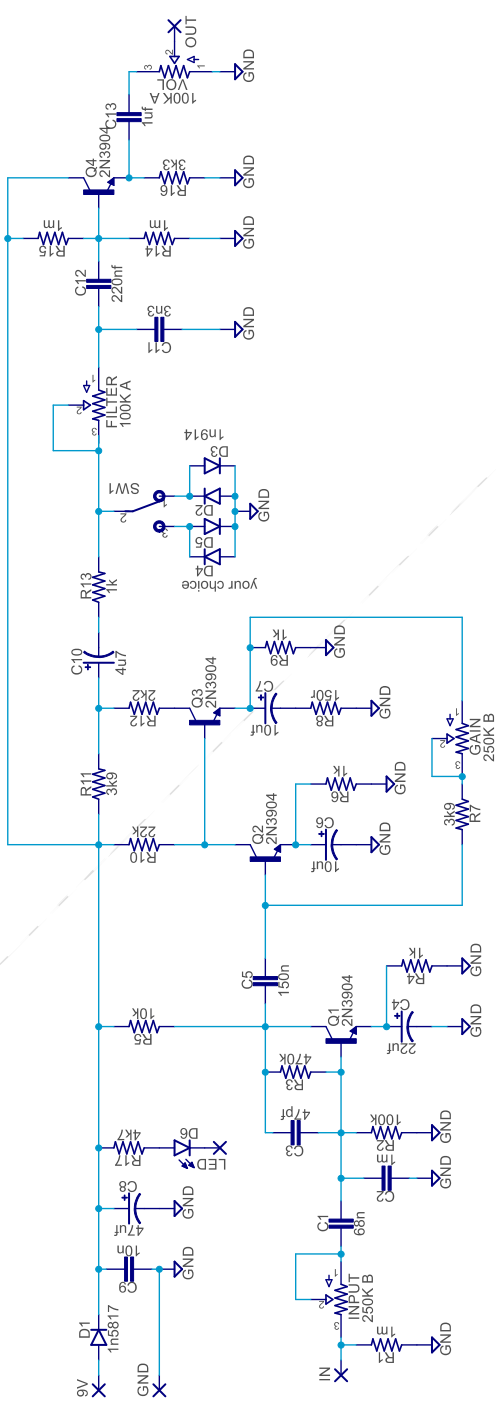

Wiring Diagram

All our projects include a free 3PDT Board to make the wiring easier and tidier. Also all of our PCBs feature the status LED on board.

The pad named “Ctrl” or “LED” is the one that controls the status of the led, wire it to the “LED” pad on the 3PDT board, or in control slug of your 3PDT.

You can take a look on the following diagram to understand the general connections. For further information check our [Pedal Wiring guide](#).

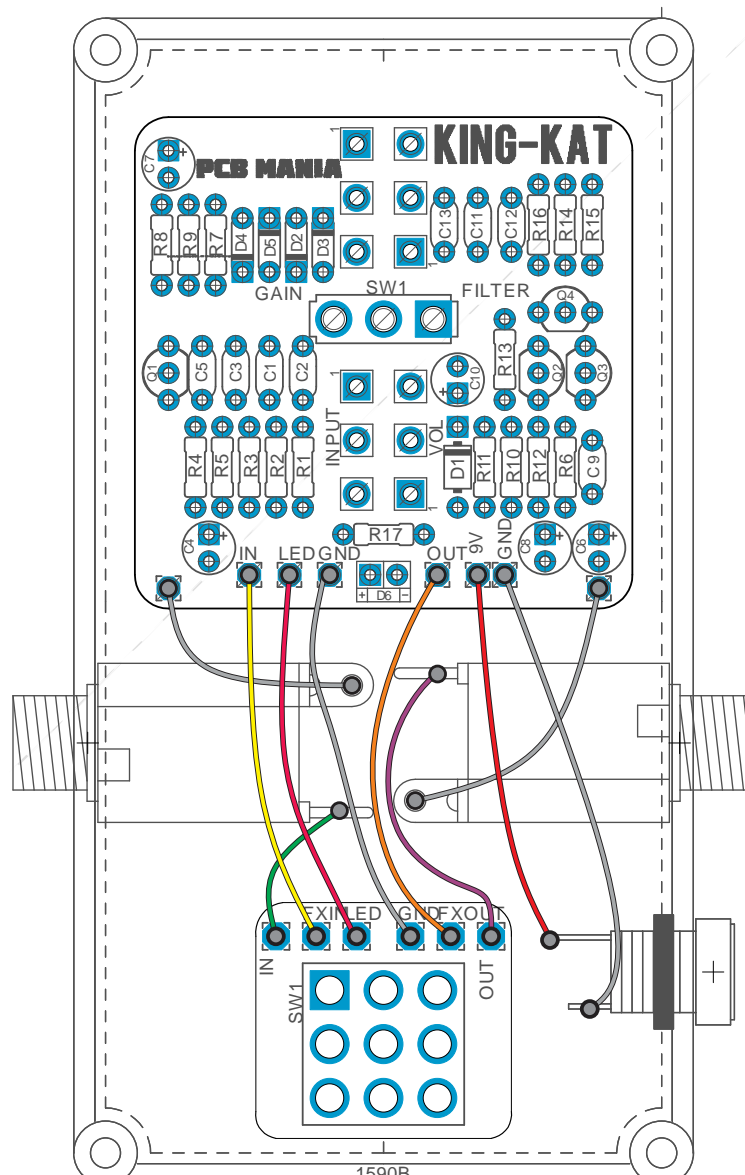

Drill Template

This Project has been planned to fit into a 1590B enclosure type (122x67x35mm approx.)

Check the Attached “Drilling templates” to drill the box properly. The files are on Scale 1:1, ready to print in an A4 page.

Licensing and Usage

We really appreciate your trust and support buying this PCB, as well as your will to dive into the DIY electronics world. That’s why for us is really important that you can make this project work properly and to enjoy not only the building process, but also to experiment and play with it on your rig.

We try to reply to every question we receive on our email or in our social media, but we try to encourage all our customers to join our [PCB Guitar Mania – Builders Group](#) on Facebook, in order to post all your doubts, issues, suggestions or request, as well to share your builds and have some feedback from us and other fellow builders!

All of our projects have been tested following this same guide on their standard configurations. Although, not all of the variations and mods have necessarily been tested. These are suggestions based on the schematic analysis, and on the experiences and opinions of others. Feel free to share with us your opinions and suggestions regarding the mods your own personal experimentation.

These boards may be used for commercial endeavors in any quantity unless specifically noted. No attribution is necessary, though accreditation or a link back is always greatly appreciated.

If you are a builder planning to make your own run of pedals we also offer the service of custom made boards with your brand and logo, design according your specifications.

The only usage restrictions are that, first, you cannot resell the PCB as part of a kit without prior arrangement with us, and second, you cannot scratch off the silk screen, or other way of trying to hide our logos and the source of the PCBs. Like it’s written above, if you want to have your own designs, with your brand and logo we could certainly reach an agreement.

Follow us on [Instagram](#) and [Facebook](#) to stay in tune with the latest projects!