

Ultimate Pharaoh

Based on:

Black Arts Toneworks Pharaoh
Supreme

Effect type:

Supreme Fuzz

Build difficult:

Average

Amount of parts:

Average, total 25 components

Technology:

Transistors cascade, Muff Type

Power consumption:

9V

Enclosure type:

1590bb

Get your board at:

[Ultimate Pharaoh](#)

Get your kit at:

[Das Musikding \(Europe\)](#)

Project overview:

The Ultimate Pharaoh is the final evolution of the legendary Pharaoh fuzz by Black arts Toneworks. The Pharaoh has long been known for its plethora of musical fuzz tones that forge a link between your guitar and amp without masking the inherent character of each. This rich legacy of tone has led many guitarists to bow down to the Pharaoh, extending its dynasty across pedalboards the world over. Now the Pharaoh Supreme ascends to the Osirian throne, promising all the tones and sounds of the original Pharaoh and much more

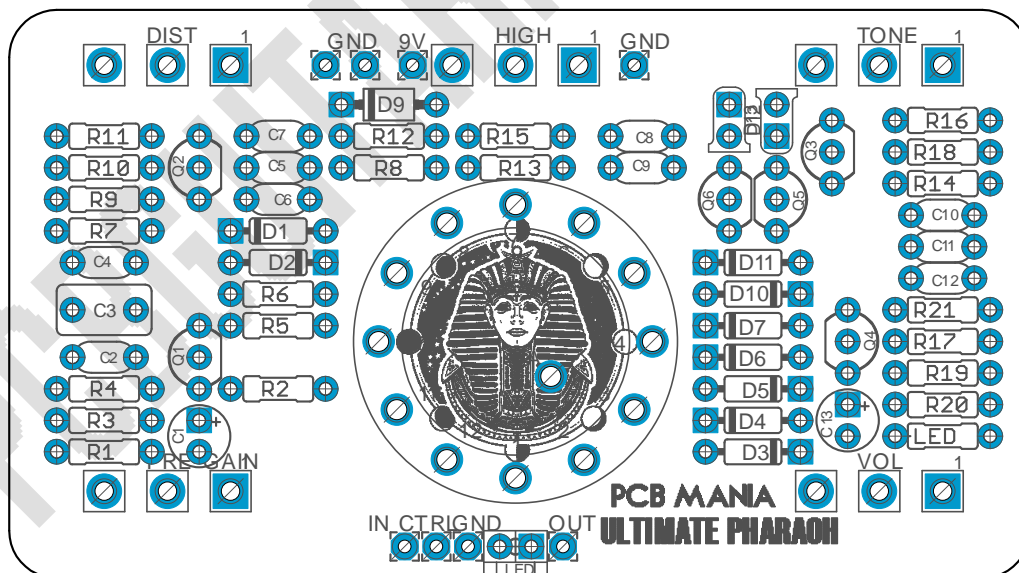

Index

1. Project overview
2. Index, Introduction & Controls
3. Bills of Materials, BOM
4. Shopping Lists
5. Components Recommendations
6. Build Notes
7. Schematic
8. Wiring Diagram
9. Drill Template
10. Licensing and Usage

Introduction

The Supreme has all of the sounds and abilities of the Standard and Primitive Pharaohs, but with some very useful additions and a bit of a twist.

The Ultimate Pharaoh replaces the Hi/Lo input switch for a variable pre input control to infinitely adjust the saturation of the front end of the circuit from 1 to 10. Following the same logic, instead of the 3 way diode selector, this version utilizes a 6 way rotary switch to select from the Standard Pharaoh diode settings, plus an additional 3 setting not available on the previous Pharaohs, allowing you to select from the following diode settings: Germanium, Asymmetrical Germanium(standard Pharaoh), Silicon (standard Pharaoh), Mosfet, LED and Bypass (standard Pharaoh).

The Pre knob control in addition to the Clip switch produce an array of sounds and textures that expand the Pharaoh into the ultimate ever produced Fuzz, definitely a build you'll be proud of.

Controls

- Fuzz control knob sets fuzz distortion level from a cleanish boost, to a light overdrive, all the way to saturated fuzz.
- Tone control knob adjusts tonality, designed to suffer little volume loss and give a natural sound.
- High control knob replenishes highs cut by the Tone control when boosting lows.
- Volume control knob sets output level.
- Pre control knob replaces the Hi/Lo switch of the standard Pharaoh and adjusts the front-end saturation between tones with more headroom/less clipping and less headroom/more clipping.
- Clip 6-position rotary knob selects from 6 different clipping stages, from left to right: Germanium, Asymmetrical Germanium (standard Pharaoh), Silicon (standard Pharaoh), Mosfet, LED, and Bypass (standard Pharaoh).

Bill of materials

Resistors	
Part	Value
R1	2M
R2	100K
R3	470K
R4	1K
R5	10K
R6	1K
R7	6K2
R8	100K
R9	100r
R10	470K
R11	10K
R12	6K2
R13	100K
R14	100r
R15	470K
R16	470K
R17	100K
R18	10K
R19	470K
R20	10K
R21	2K2
R-LED	4k7

Capacitors	
Part	Value
C1	10uf
C2	470p
C3	470n
C4	47n
C5	470p
C6	47n
C7	47n
C8	470p
C9	47n
C10	10n
C11	22n
C12	47n

C13	10uf
-----	------

Diodes	
Part	Value
D1	1N4148
D2	1N4148
D3	1n4001
D4	1n4001
D5	1n34A
D6	1n34A
D7	1n34A
D9	1n5817
D10	1n270
D11	1n270
D12	3mm RED LED
D13	3mm RED LED
LED	3mm RED LED

Potentiometers	
Part	Value
TONE	250K B
VOL	100K B
PRE-GAIN	500K B
DIST	100K B
HIGH	25K B

Transistors	
Part	Value
Q1	2N5089
Q2	2N5089
Q3	2N5089
Q4	2N5089
Q5	2N7000
Q6	2N7000

Switches		
Qty	Value	Parts
1	1P12T	SW1

Shopping list

Resistors		
Qty	Value	Parts
1	2M	R1
4	100K	R2, R8, R13, R17
1	2K2	R21
5	470K	R3, R10, R15, R16, R19
2	1K	R4, R6
4	10K	R5, R11, R18, R20
2	6K2	R7, R12
2	100r	R9, R14
1	4k7	R-LED

Capacitors		
Qty	Value	Parts
2	10uf	C1, C13
1	10n	C10
1	22n	C11
3	470p	C2, C5, C8
1	470n	C3
5	47n	C4, C6, C7, C9, C12

Diodes		
Qty	Value	Parts
2	1N4148	D1, D2
2	1n270	D10, D11
3	3mm RED LED	D12, D13, LED
2	1n4001	D3, D4
3	1n34A	D5, D6, D7
1	1n5817	D9

Transistors		
Qty	Value	Parts
3	2N5089	Q2, Q3, Q4
2	2N7000	Q5, Q6
1	MPSA18	Q1

Switches		
Qty	Value	Parts
1	1P12T	SW1

Potentiometers		
Qty	Value	Parts
1	250K B	TONE
2	100K B	DIST, VOL
1	25K B	HIGH
1	500KB	PRE-GAIN

Components Recommendations

As many people like to experiment some pedals with higher voltage, always ensure the max tolerance of your **electrolytic capacitors** is over 25v.

This board has been tested using Film box capacitors for most of the values over 1nf, and ceramics discs for the ones under 1nf. However, high quality components such as Wima's Capacitors and Panasonic's electrolytics can deliver a better performance.

All the resistors used for testing this project are 1/4W Metal Film.

The BOM and Shopping list are exclusively regarding this project. It doesn't include all the hardware like the 3PDT bypass switch, audio/dc jacks, enclosure, etc.

Building Notes

For a successful and tidy build it's recommended the following order:

1. Resistors & diodes
2. Capacitors, starting with the smaller ones and the ceramic ones.
3. Electrolytic capacitors (always check the polarity)
4. Transistors
5. Wires
6. Potentiometers and switches
7. Off board wiring

The 1P12T rotary switch includes a washer that allows you to limit the amount of available positions. For this project we are going to set our Switch on 6 positions.

For the correct functionality of this project you must place a wire in between the terminal 6 of the rotary switch and D11 as is indicated on the graphic.

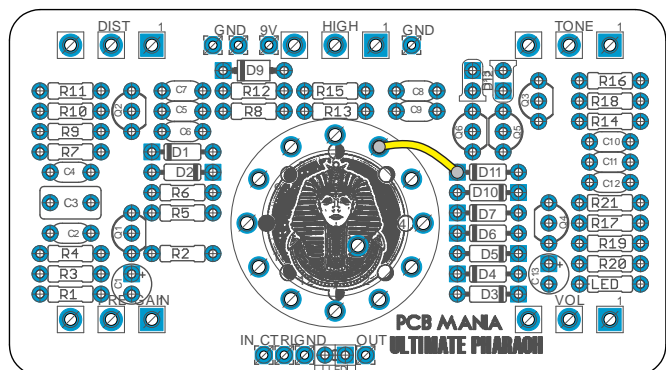

Schematic

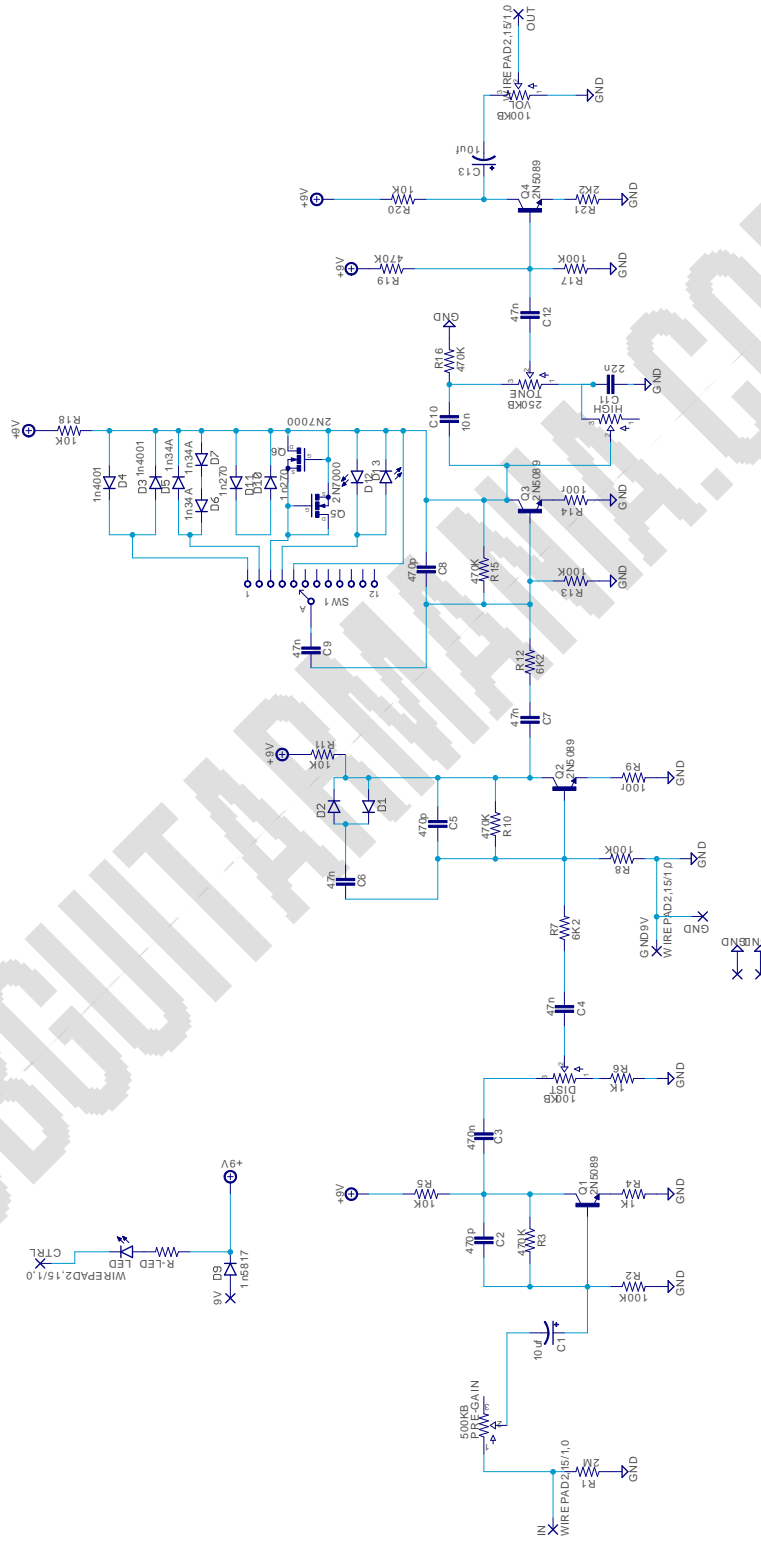

Wiring Diagram

All our projects include a free 3PDT Board to make the wiring easier and tidier. Also all of our PCBs feature the status LED on board.

The pad named “Ctrl” or “LED” is the one that controls the status of the led, wire it to the “LED”pad on the 3PDT board, or in control slug of your 3PDT.

This board has been designed to match our EZ 3PDT PCB check it [here](#) to access to our [Pedal Wiring Guide](#)

Drill Template

This Project has been planned to fit into a 1590b enclosure type.

Check the Attached “Drilling templates” to drill the box properly. The files are on Scale 1:1, ready to print in an A4 page.

Licensing and Usage

We really appreciate your trust and support buying this PCB, as well as your will to dive into the DIY electronics world. That’s why for us is really important that you can make this project work properly and to enjoy not only the building process, but also to experiment and play with it on your rig.

We try to reply to every question we receive on our email or in our social media, but we try to encourage all our customers to join our [PCB Guitar Mania – Builders Group](#) on Facebook, in order to post all your doubts, issues, suggestions or request, as well to share your builds and have some feedback from us and other fellow builders!

All of our projects have been tested following this same guide on their standard configurations. Although, not all of the variations and mods have necessarily been tested. These are suggestions based on the schematic analysis, and on the experiences and opinions of others. Feel free to share with us your opinions and suggestions regarding the mods your own personal experimentation.

These boards may be used for commercial endeavors in any quantity unless specifically noted. No attribution is necessary, though accreditation or a link back is always greatly appreciated.

If you are a builder planning to make your own run of pedals we also offer the service of custom made boards with your brand and logo, design according your specifications.

The only usage restrictions are that, first, you cannot resell the PCB as part of a kit without prior arrangement with us, and second, you cannot scratch off the silk screen, or other way of trying to hide our logos and the source of the PCBs. Like it’s written above, if you want to have your own designs, with your brand and logo we could certainly reach an agreement.

Follow us on [Instagram](#) and [Facebook](#) to stay in tune with the latest projects!