

Black Musket

Based on:	Amount of parts:	Enclosure type:
Blackout effectors Musket Fuzz	High, total 65 components	125b
Effect type:	Technology:	Get your board at:
Heavy modified big muff fuzz	4 gain stages + LPB-1 booster	Black Musket
Build difficult:	Power consumption:	Get your kit at:
Average	9V(9mA)	Das Musikding (Europe)

Project overview:

Critically acclaimed boutique Big Muff. Based on a Black Russian version, the Musket adds a modified LPB-1 booster (the "Pre" section) that pushes the standard BMP circuit. Featuring MIDS-shaping control, and FOCUS knob for the sub-low end frequencies address all of the commonly discussed shortcomings of the old 3-knob fuzz. From Floyd-ian singing violin sustain to dreamy, grungy growl; the flexibility is all there at your fingertips.

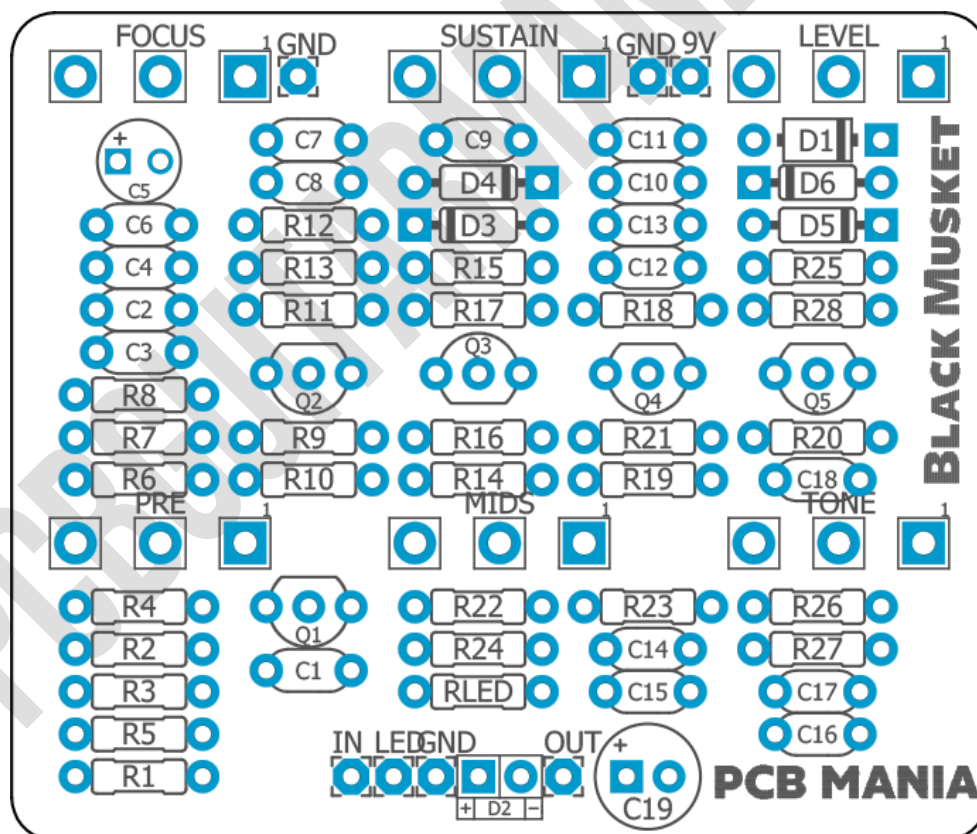

Index

1. Project overview
2. Index, Introduction & Controls
3. Bills of Materials, BOM
4. Shopping Lists
5. Components Recommendations
6. Build Notes
7. Schematic
8. Wiring Diagram
9. Drill Template
10. Licensing and Usage

Introduction

You are looking to build THE Fuzz but want some clever extras? The Blackout effectors Musket Fuzz™ is based on the Russian Muff but adds plenty little helpers added to that famous circuit known for its endless sustain. So it can sound like many different version of the Big M but still gives you full control over the capabilities of the circuit. The Focus knob cuts low end to tighten the attack for a more modern fuzz sound. That's not only fun for guitar players. It also lets the dudes on the bass join the party. The tone control has an extra dedicated mids knob to prevent you from getting lost in a band situation. The Pre knob lets you add extra gain and can sound like you are stacking an overdrive before the fuzz. Volume, tone and gain give you the controls you used to have on this kind of pedal and allows you to dial in the classic sounds you expect.

Controls

- Level
- Sustain
- Focus
- Pre
- Mids
- Tone

Bill of materials

Resistors	
Part	Value
R1	1M
R2	470K
R3	47K
R4	10K
R5	390R
R6	10K
R7	13K
R8	100K
R9	100R
R10	470K
R11	12K
R12	1K
R13	10K
R14	100K
R15	470K
R16	390R
R17	12K
R18	10K
R19	100K
R20	390R
R21	470K
R22	12K
R23	10K
R24	56K
R25	470K
R26	100K
R27	2K7
R28	10K
RLED	4K7

Potentiometers	
Part	Value
FOCUS	B250K
LEVEL	A100K
MIDS	A100K
PRE	A100K
SUSTAIN	A100K
TONE	B250K

Capacitors	
Part	Value
C1	100n
C2	100n
C3	100n
C4	10n
C6	470p
C7	100n
C8	100n
C9	470p
C10	100n
C11	100n
C12	470p
C13	100n
C14	3.3n
C15	47n
C16	47n
C17	100n
C18	100n

Electrolytics Capacitors	
Part	Value
C5	1u
C19	100u

Transistors	
Part	Value
Q1	2N5089
Q2	2N5089
Q3	2N5089
Q4	2N5089
Q5	2N5089

Diodes	
Part	Value
D1	1N5817
D2	3 mm
D3	1n914
D4	1n914
D5	1n914
D6	1n914

Shopping list

Resistors		
Qty	Value	Parts
4	100K	R8, R14, R19, R26
1	100R	R9
6	10K	R4, R6, R13, R18, R23, R28
3	12K	R11, R17, R22
1	13K	R7
1	1K	R12
1	1M	R1
1	2K7	R27
3	390R	R5, R16, R20
5	470K	R2, R10, R15, R21, R25
1	47K	R3
1	4K7	RLED
1	56K	R24

Capacitors		
Qty	Value	Parts
10	100n	C1, C2, C3, C7, C8, C10, C11, C13, C17, C18
1	10n	C4
1	3.3n	C14
3	470p	C6, C9, C12
2	47n	C15, C16

Electrolytics Capacitors		
Qty	Value	Parts
1	100u	C19
1	1u	C5

Potentiometers		
Qty	Value	Parts
4	A100K	LEVEL, MIDS, PRE, SUSTAIN
2	B250K	FOCUS, TONE

Transistors		
Qty	Value	Parts
5	2N5089	Q1, Q2, Q3, Q4, Q5

Diodes		
Qty	Value	Parts
1	1N5817	D1
4	1n914	D3, D4, D5, D6
1	LEDSTATUS-LED	D2

Components Recommendations

As many people like to experiment some pedals with higher voltage, always ensure the max tolerance of your **electrolytic capacitors** is over 25v.

This board has been tested using Film box capacitors for most of the values over 1nf, and ceramics discs for the ones under 1nf. However, high quality components such as Wima's Capacitors and Panasonic's electrolytics can deliver a better performance.

All the resistors used for testing this project are 1/4W Metal Film.

The BOM and Shopping list are exclusively regarding this project. It doesn't include all the hardware like the 3PDT bypass switch, audio/dc jacks, enclosure, etc.

Build Notes

If this is one of your first projects I recommend you to take a look on our [Pedal Building Guide](#)

For a successful and tidy build it's recommended the following order:

1. Resistors & diodes
2. Capacitors, starting with the smaller ones and the ceramic ones.
3. Electrolytic capacitors (always check the polarity)
4. Transistors
5. Wires
6. Potentiometers and switches
7. Off board wiring

Schematic

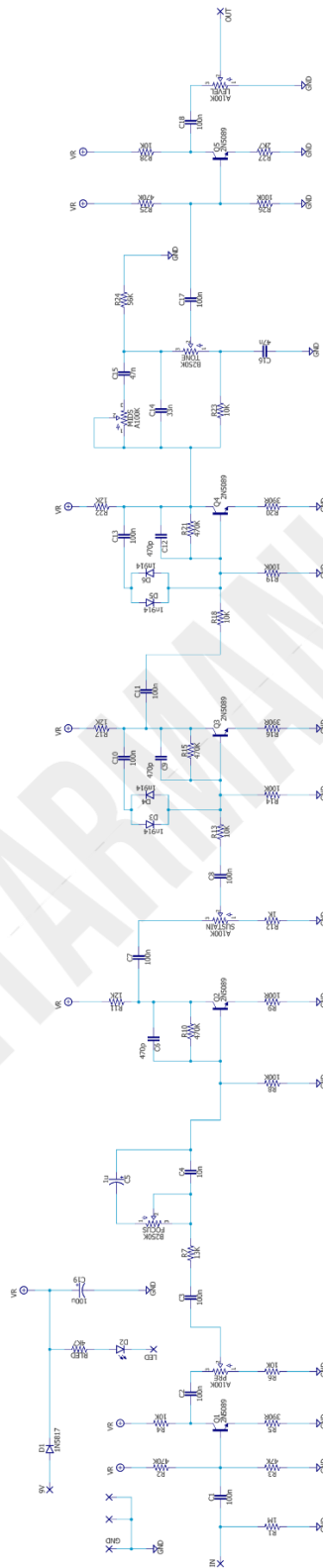

Wiring Diagram

All our projects include a free 3PDT Board to make the wiring easier and tidier. Also all of our PCBs feature the status LED on board.

The pad named “Ctrl” or “LED” is the one that controls the status of the led, wire it to the “LED” pad on the 3PDT board, or in control slug of your 3PDT.

This board has been designed to match our EZ 3PDT PCB check it [here](#) to access to our [Pedal Wiring Guide](#)

Drill Template

This Project has been planned to fit into a 1590bb enclosure type.

Check the Attached “Drilling templates” to drill the box properly. The files are on Scale 1:1, ready to print in an A4 page.

Licensing and Usage

We really appreciate your trust and support buying this PCB, as well as your will to dive into the DIY electronics world. That’s why for us is really important that you can make this project work properly and to enjoy not only the building process, but also to experiment and play with it on your rig.

We try to reply to every question we receive on our email or in our social media, but we try to encourage all our customers to join our [PCB Guitar Mania – Builders Group](#) on Facebook, in order to post all your doubts, issues, suggestions or request, as well to share your builds and have some feedback from us and other fellow builders!

All of our projects have been tested following this same guide on their standard configurations. Although, not all of the variations and mods have necessarily been tested. These are suggestions based on the schematic analysis, and on the experiences and opinions of others. Feel free to share with us your opinions and suggestions regarding the mods your own personal experimentation.

These boards may be used for commercial endeavors in any quantity unless specifically noted. No attribution is necessary, though accreditation or a link back is always greatly appreciated.

If you are a builder planning to make your own run of pedals we also offer the service of custom made boards with your brand and logo, design according your specifications.

The only usage restrictions are that, first, you cannot resell the PCB as part of a kit without prior arrangement with us, and second, you cannot scratch off the silk screen, or other way of trying to hide our logos and the source of the PCBs. Like it’s written above, if you want to have your own designs, with your brand and logo we could certainly reach an agreement.

Follow us on [Instagram](#) and [Facebook](#) to stay in tune with the latest projects!