

# Octavius

**Based on:**

Tycobrahe Octavia

**Effect type:**

Vintage octave fuzz

**Build difficult:**

Average

**Amount of parts:**

Average, total 32 components

**Technology:**

Silicon transistors + Transformer

**Power consumption:**

9V

**Enclosure type:**

125b

**Get your board at:**

[Octavius](#)

**Get your kit at:**

[Das Musikding \(Europe\)](#)

**Project overview:**

Inspired by one of Tycobrahe's most famous and distinctive designs. Frequently used by Jimy Hendrix, this pedal produces a fuzz sound that is one octave higher than the note you are currently playing, delivering unique tones in the process.

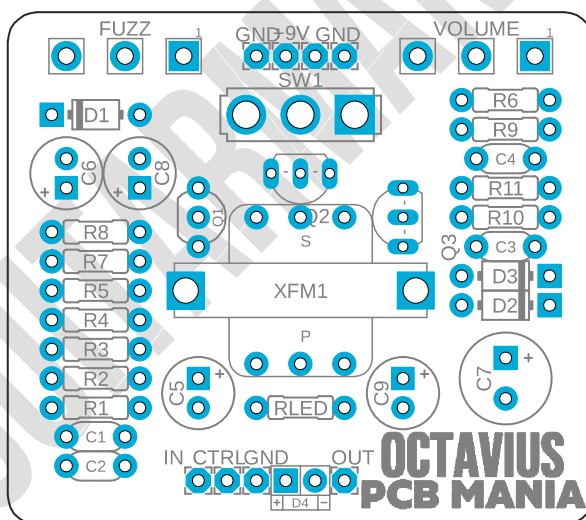

# Index

---

1. Project overview
2. Index, Introduction & Controls
3. Bills of Materials, BOM
4. Shopping Lists
5. Components Recommendations
6. Build Notes
7. Schematic
8. Wiring Diagram
9. Drill Template
10. Licensing and Usage

## Introduction

---

This classic circuit originated in early 1967 is an analog board with the properties of a frequency doubler, envelope generator, and amplitude modulator with additional frequency shaping filter circuits. Its features can be recognized in many of Jimi Hendrix's recordings just as "Purple Haze", "Fire", "One Rainy Wish", "Little Miss Lover", "Little Wing", "Machine Gun", and several others.

The pedal produces a clean fuzz that will allow the octave sound to go through, and when you put some chord on it, you can hear that great ring modulation sound happening.

We also added an "octave lift" switch so you can use it without the octave overtones for added flexibility. If you prefer to keep it loyal to the original, just wire a jumper between pads 1 and 2 of the switch silkscreen.

This easy-to-build board will allow you to have one of the most collectible vintage pedals out there.

## Controls

---

- Fuzz
- Volume

# Bill of materials

---

Resistors	
Part	Value
R1	1M
R2	680K
R3	680K
R4	180K
R5	220K
R6	220R
R7	1K
R8	47K
R9	470R
R10	22K
R11	1K2
RLED	4K7

Transistors	
Part	Value
Q1	2n5087
Q2	2N4401
Q3	2N4401

Transformer	
Part	Value
XFM1	42TM022

Switches	
Part	Value
SW1	SPDT ON/ON

Capacitors	
Part	Value
C1	100n
C2	150p
C3	1n
C4	100n

Diodes	
Part	Value
D1	1n5817
D2	1n34a
D3	1n34a
LED	3mm Red LED

Electrolytics Capacitors	
Part	Value
C5	33u
C6	100u
C8	33u
C9	100u

Potentiometers	
Part	Value
FUZZ	1K B
VOLUME	500K A

# Shopping list

---

Resistors		
Qty	Value	Parts
1	180K	R4
1	1K	R7
1	1K2	R11
1	1M	R1
1	220K	R5
1	220R	R6
1	22K	R10
1	470R	R9
1	47K	R8
1	4K7	RLED
2	680K	R2, R3

Capacitors		
Qty	Value	Parts
2	100n	C1, C4
1	150p	C2
1	1n	C3

Electrolytics Capacitors		
Qty	Value	Parts
2	100u	C6, C9
2	33u	C5, C8

Potentiometers		
Qty	Value	Parts
1	500K A	VOLUME
1	1K B	FUZZ

Transistors		
Qty	Value	Parts
2	2N4401	Q2, Q3
1	2n5087	Q1

Transformer		
Qty	Value	Parts
1	42TM022	XFM1

Switches		
Qty	Value	Parts
1	SPDT ON/ON	SW1

Diodes		
Qty	Value	Parts
2	1n34a	D2, D3
1	1n5817	D1
1	3mm Red LED	LED

# Schematic

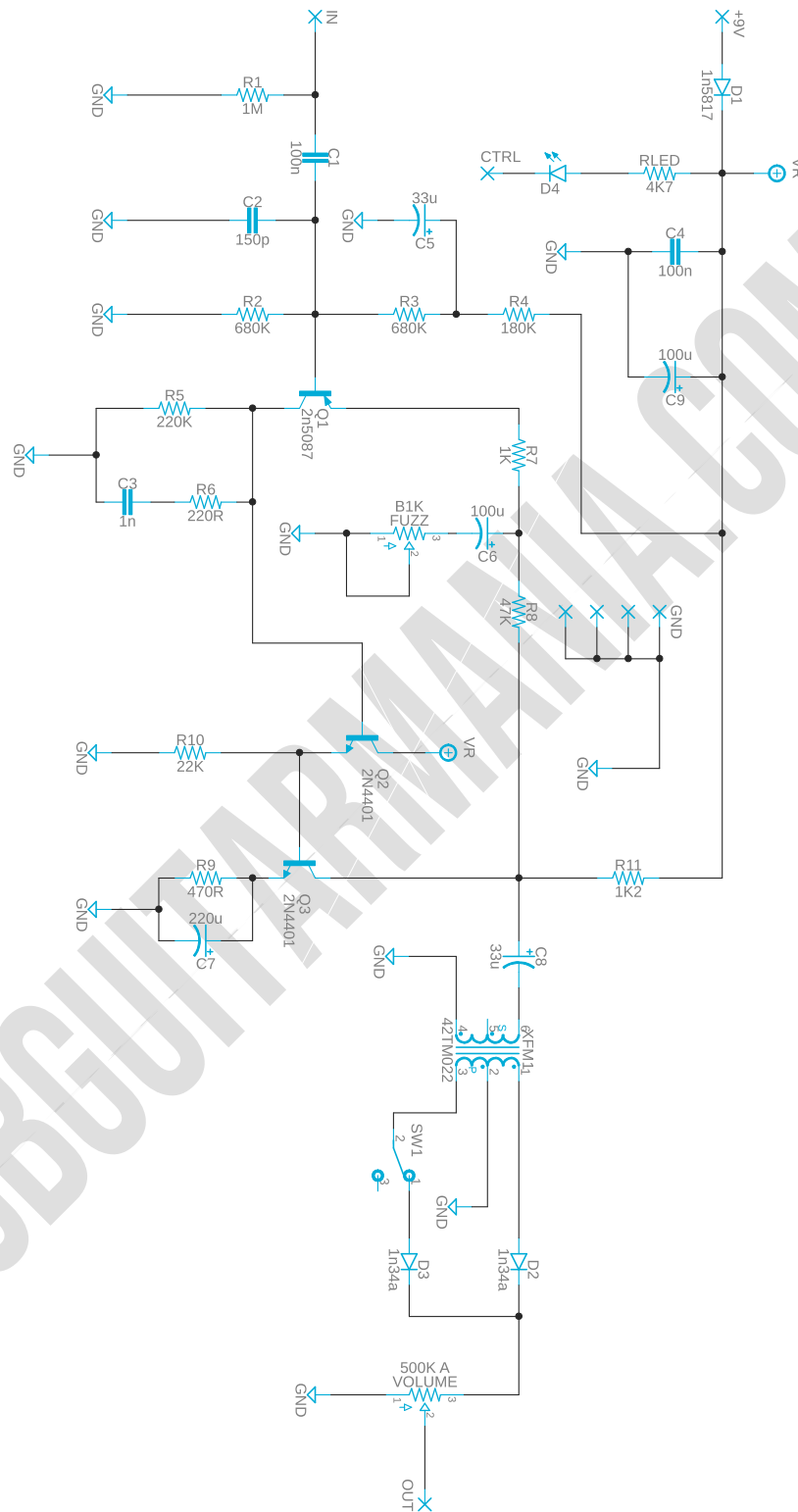

# Components Recommendations

---

As many people like to experiment with some pedals with higher voltage, always ensure your **electrolytic capacitors'** max tolerance is over 25v.

This board has been tested using Film box capacitors for most of the values over 1nf and ceramics discs for those under 1nf. However, high-quality components such as Wima's Capacitors and Panasonic's electrolytics can deliver a better performance.

All the resistors used for testing this project are 1/4W Metal Film.

The BOM and Shopping list are exclusive regarding this project. It doesn't include all the hardware like the 3PDT bypass switch, audio/dc jacks, enclosure, etc.

## Build Notes

---

If this is one of your first projects, I recommend you to take a look at our [Pedal Building Guide](#).

For a successful and tidy build, it's recommended the following order:

1. Resistors & diodes
2. Capacitors, starting with the smaller ones and the ceramic ones.
3. Electrolytic capacitors (always check the polarity)
4. Transistors
5. Wires
6. Potentiometers and switches
7. Off-board wiring

## Wiring Diagram

---

All our projects include a free 3PDT Board to make the wiring easier and tidier. Also, all of our PCBs feature the status LED on board.

The pad named "Ctrl" or "LED" is the one that controls the status of the led; wire it to the "LED" pad on the 3PDT board or in the control slug of your 3PDT.

This board has been designed to match our EZ 3PDT PCB; check it [here](#) to access our [Pedal Wiring Guide](#).

# Drill Template

---

This Project has been planned to fit into a 125b enclosure type.

Check the Attached “Drilling templates” to drill the box properly. The files are on Scale 1:1, ready to print on an A4 page.

## Licensing and Usage

---

We really appreciate your trust and support in buying this PCB, as well as your will to dive into the DIY electronics world. For us, that's why you can make this project work properly and enjoy not only the building process but also experiment and play with it on your rig.

We try to reply to every question we receive on our email or our social media. Still, we try to encourage all our customers to join our [PCB Guitar Mania - Builders Group](#) on Facebook to post all your doubts, issues, suggestions, or requests, share your builds, and have some feedback from other fellow builders and us!

We tested all our projects following this same guide on their standard configurations. Although, not all of the variations and mods have necessarily been checked. These are suggestions based on the schematic analysis and the experiences and opinions of others. Feel free to share with us your views and recommendations regarding the mods your personal experimentation.

These boards may be used for commercial endeavors in any quantity unless expressly noted. No attribution is necessary, though accreditation or a link back is always much appreciated.

If you are a builder planning to make your own run of pedals, we also offer the service of custom-made boards with your brand and logo, design according to your specifications.

The only usage restrictions are that, first, you cannot resell the PCB as part of a kit without prior arrangement with us, and second, you cannot scratch off the silkscreen or other way of trying to hide our logos and the source of the PCBs. Like it's written above, if you want to have your designs with your brand and logo, we could undoubtedly reach an agreement.

Follow us on [Instagram](#) and [Facebook](#) to stay in tune with the latest projects!