

Pedal Wiring Guide

1. Free 3PDT and hardware explained.
2. Order Switch explained
3. Audio and DC jacks
4. Standard wiring
5. Dual effects wiring
6. Dual effect with master Bypass
7. Dual Effects with order switch
8. Schematics

1. EZ 3PDT explained

We like to include a Free EZ 3PDT board along with each of our projects, even two for the dual effect! This boards will help you to make the wiring process much more easily and also to keep your build much more tidy and professional looking.

Also if you want to get some extra EZ 3PDT boards for your other projects you can check them on the following [link](#).

Each board has the following pads:

IN: Is the pedal main input, it goes to hot tip of the input audio jack.

FX IN: Goes to the effect PCB input, the pad called IN on the effect board.

LED: This controls the ON-OFF of the status LED. Basically it takes it to Ground when the switch is engaged closing the LED circuit and turning it on.

GND: Ground. Remember that you must have always all the grounds wired to a common ground, usually the enclosure. So make sure the effect board, the 3pdt board, the negative tip of the DC jack are somehow connected to the sleeve of your jacks, because this one is in permanent contact with the enclosure and the other sleeve, closing this way the ground circuit. If you don't have your grounding properly done your effect will not work correctly.

FX OUT: Goes to the effect PCB output, the pad Called OUT on the effect board.

OUT: is the Pedal main Output, it goes to the hot tip of the Output audio Jack.

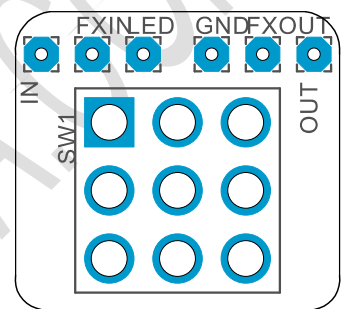

3. AUX 3PDT explained

Selecting This board will help you with the wiring process of projects with a 9 PIN 3PDT Pedal Stomp Foot Switch connection.

Like with the EZ 3PDT, we like to include a Free AUX 3PDT board along with each of our projects that need it for you to have a smooth, tidy, professional-looking build.

If you want to get some extra AUX 3PDT boards for your other projects, you can check them on the following [link](#).

Alternatively, the following wiring diagram indicates how to wire the 9 PIN 3PDT Pedal Stomp Foot Switch directly to the main board without needing to use an AUX3PDT board.

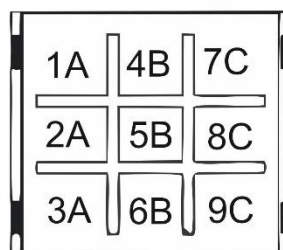
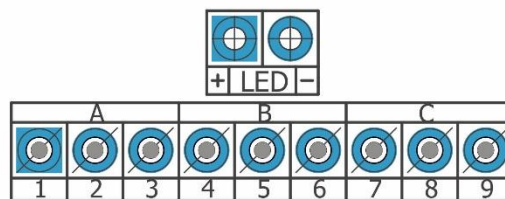
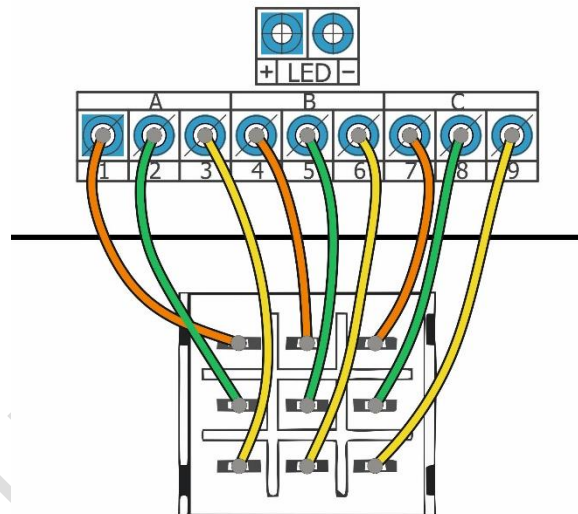
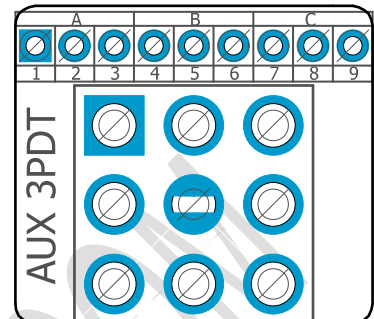

3. Order Switch explained

Selecting the order of through two effects on the same enclosure is an easy task with our Order switch PCB. This board works along with a 3PDT switch, it could be a regular stomp switch or just an ON-ON 3pdt toggle, or you can even make a standalone unit for rewiring different pedals in your chain.

Basically the order switch has one main Input and a main Output where the signal input from the audio jacks must be connected. Then we have two different circuits' paths A and B with their own respective in and out.

So let's take a look on how this board should be wired.

Input: Goes to the main audio input jack

Output: Goes to the main audio output jack

In-A: Goes to the EZ 3PDT PAD "IN" of the circuit A

Out-A: Goes to the EZ 3PDT PAD "OUT" of the circuit A

In-B: Goes to the EZ 3PDT PAD "IN" of the circuit B

Out-B: Goes to the EZ 3PDT PAD "OUT" of the circuit B

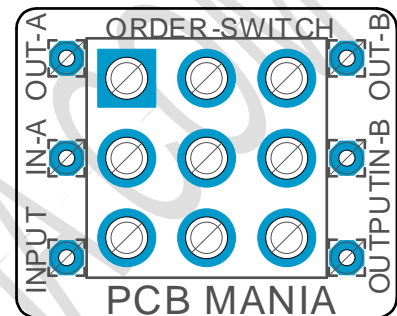

You can check bellow on the page 7 a graphic example showing you how to wire two effects with the order switch.

Another possible application of this board is as an standalone rewiring unit, just by considering the pads In-A and Out-A as "Send-A" and "Return-A" and wire those terminals into the hot tip of two different audio jacks. Same goes for the path B. The final result will be a 6 jacks behemoth, two jacks for the main Input and Output, two jacks for the Send and Return for path A, and two jacks for Send and Return for path B.

4. Audio and DC jacks

There are many different audio and DC jacks, but all of them share this basic thing in common; both of them have at least two different terminals, a hot tip and a negative one or sleeve. Here we are going to explain the most common ones used on the pedal building world

6.35 (1/4) Audio Jack

On the following pic you can see the anatomy of the audio connectors we use daily on our pedals.

The Tip is or Hot terminal, is where the audio comes in or goes out. You can recognize it easily just by looking at the jack, because the tip is always connected to the “hook” of our jack. The Hook and the hot tip are always connected in between them, so if you have any doubt about your jacks tips you can always use your tester to measure continuity in between the hook and the tips, it will buzz when you touch the right one!

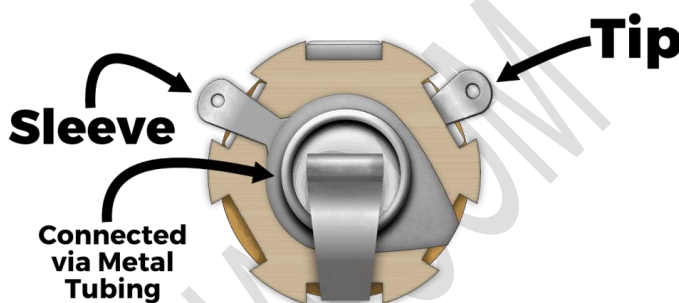

The sleeve is the ground of our jack, you can recognize this one because it is connected via metal tubing to the inside of the jack and it's the one that is always touching the enclosure, so it makes perfect sense that we always wire the grounds of our build here.

DC JACK

First of all it's really important to say that it's strongly recommended to always use plastic jacks on our builds, this is because the standard of pedals and power supplies are designed for a Center Negative supply, this means that we have the positive on the “external part of our DC Jack”, so if we are using a metal jack touching the enclosure (ground) we will be literally grounding our 9v supply.

Here on this graphic you can see which pin does what on a Center Negative connection.

The negative tip (1) will be connected to ground.

The positive tip (2, 3) is in charge of feeding the pedal with power, it always goes to the 9v pad on the effect board.

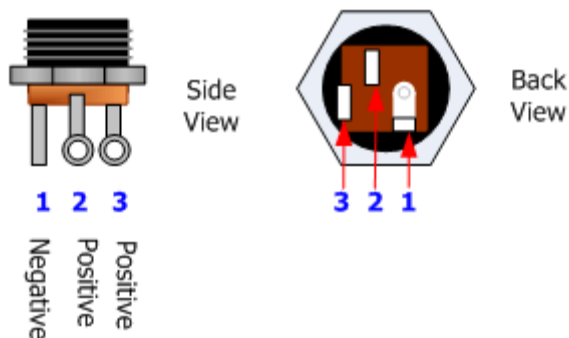

5. Standard Wiring

In the following example of the standard wiring using our provided 3PDT boards you can see the most common set up for our projects.

Let's explain a bit what's going on here:

On each design we respect the same pads and the order of them when it's possible, so this example is valid for almost each of our projects.

IN: Is the input of the effect, it's wired to the PAD "FX IN" of the 3PDT Board.

CTRL (Sometimes LED on the first designs): This controls the ON-OFF of the status LED. Basically it take it to Ground when the switch is engaged so close the LED circuit and turns it on.

GND: Ground, we have at least two ground pads on each of our boards, and we are adding as much as we can on the new projects in order to make the wiring process much easier. You just need to wire one of all the GND pads on board, but without doubt the extra ones will make this task much easier.

The key is to have always all the grounds wired to a common ground, usually the enclosure. So make sure the effect board, the 3pdt board, the negative tip of the DC jack are somehow connected to the sleeve of your jacks, because this one is in permanent contact with the enclosure and the other sleeve, closing this way the ground circuit. If you don't have your grounding properly done your effect will not work correctly.

LED: In each of our designs we include the status LED on board. Feel free to experiment with any different size or color, the classic standard is 3mm Red LED, but feel free to try whatever you want like a 5mm Blue LED or a 2mm square green LED. The key is to place it on the bottom side of the PCB, and not on the top component face. I always recommend to place this one at last, once you are boxing your pedal inside the enclosure. On some of our boards this LED is simply call with a Dx, but you can always recognize is the status LED by the position in the middle bottom of the board.

Out: Is the Output of the effect, it's wired to the PAD "FX OUT" of the 3PDT Board.

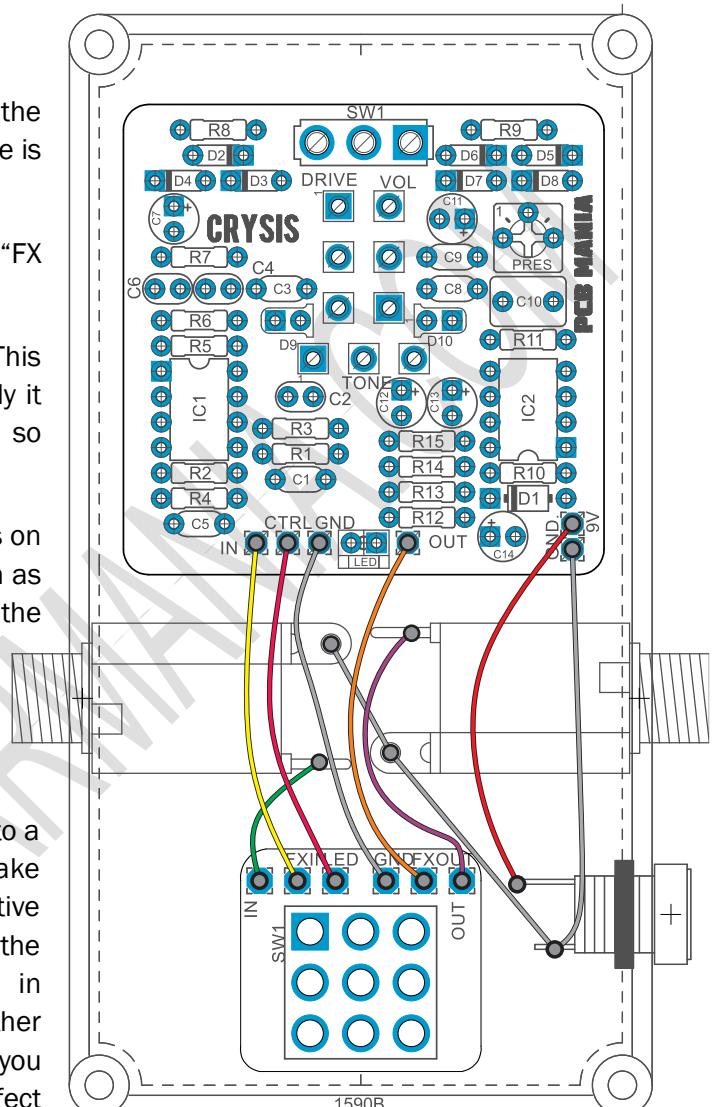

6. Dual Effects

The following set-up makes both parts of the circuit to work independently of each other, so you can be using just the booster side, with the drive in bypass mode.

There are many of our boards that are actually two effects in one PCB, such as a drive and boost like the Triple Wicked, or the Ojo Diablo (pictured), or like KoT, two overdrives in a row.

Wiring dual effects, or just two simple circuits in one board isn't as hard as many people think, it's simply as the output of one circuit is feeding the input of the other as you can see in the Ojo Diablo Example.

The part that receives the signal from the input jack would be the first effect on the chain, while the one that receive the input from the first PCB will be second. Take this in mind at the time of experimenting with your own combinations, think about which should go first, because for example a booster in front of an overdrive will increase the body and the gain of your tone, but without any considerable raise on the volume, while if you place it after the overdrive you will hear how it raise the volume with adding dirt on it.

But if experimentation is your thing we have prepared also the guide to wire them with an Order switch, so you can experiment with different combinations.

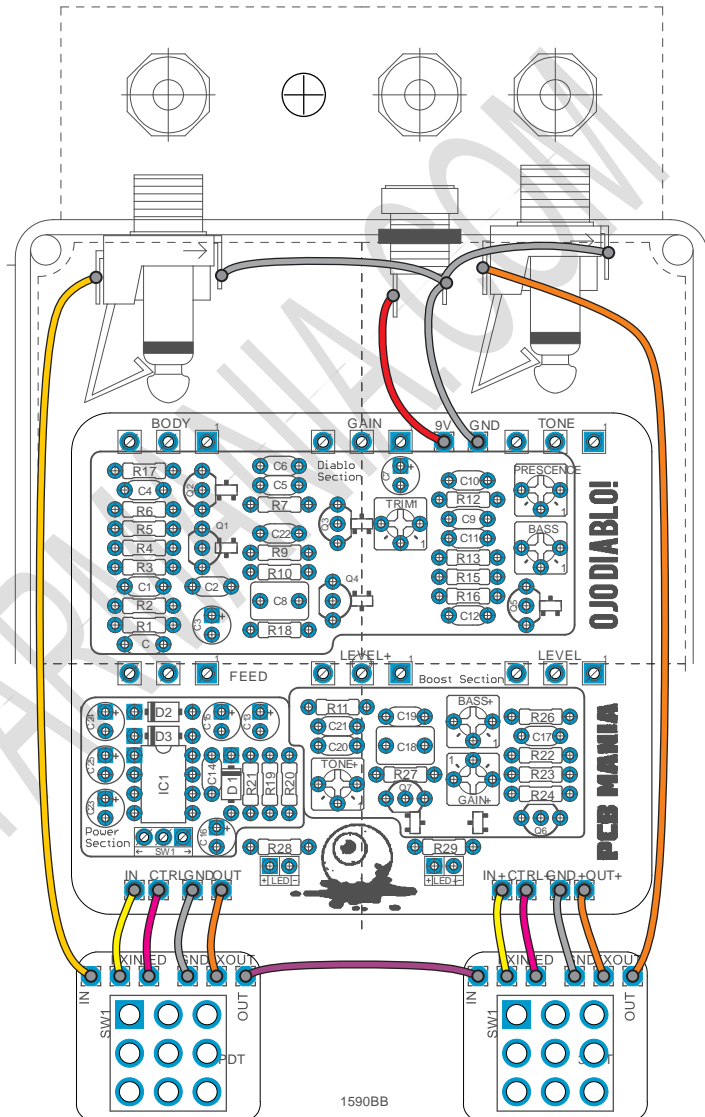

7. Dual effect with master Bypass

This version shows an optional switchable effect (such as a booster) before the main board. The main stomp will bypass everything, the second stomp will turn the booster on and off. If you want the booster after the main effect, solder the input side up as usual and take the main board output to the second stomp instead.

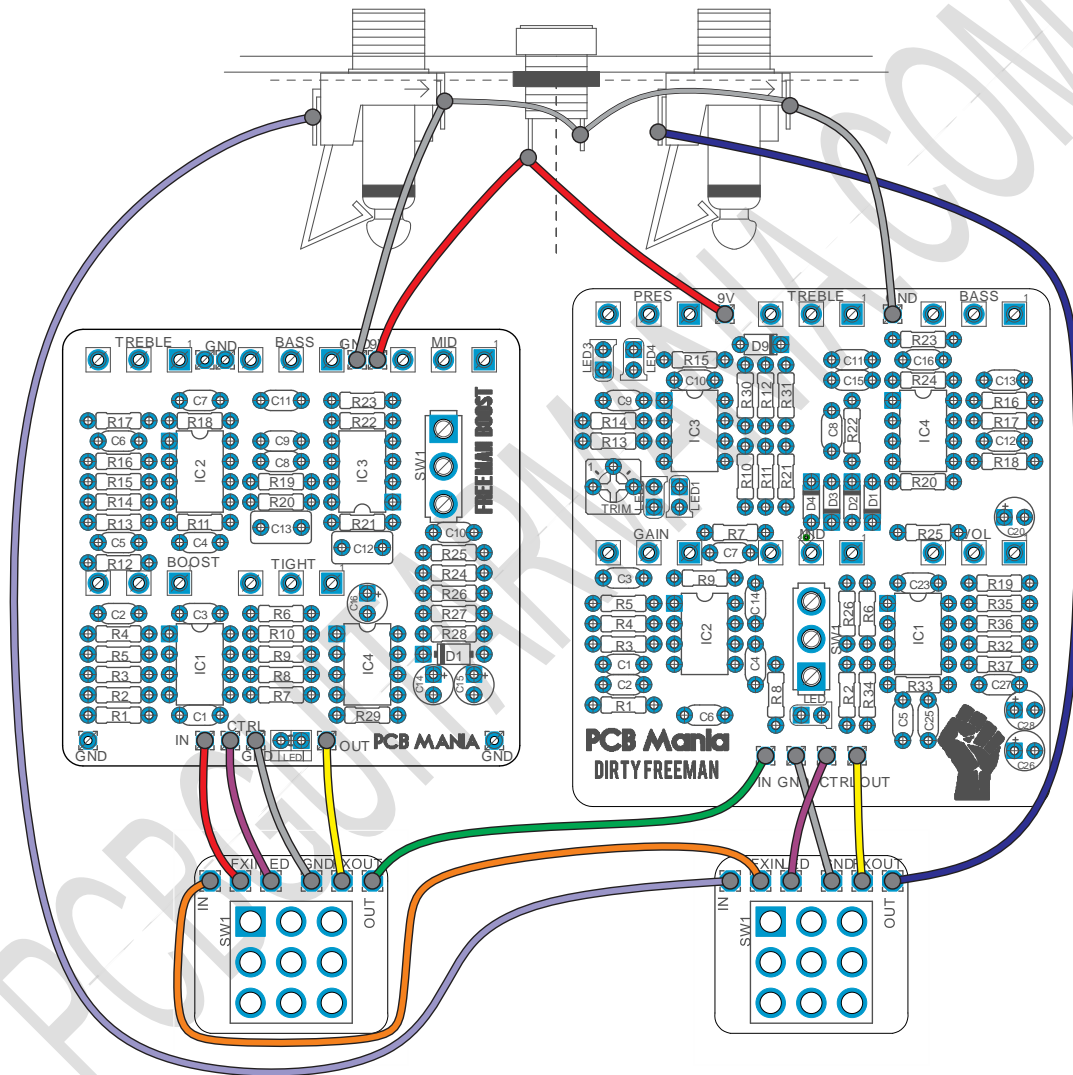

Here in this example we can see the Dirty Freeman as the main board, while the Freeman Boost goes before. Also take note of this layout if you plan to wire two effects on the same enclosure; you can always feed both PCBs with a single DC jack.

8. Dual Effects with order switch

The last wiring diagram that we are going to cover in this guide features our [Order Switch PCB](#), which allows you to change the orders of the effects in the chain. This switch could be either a regular 3PDT or a Toggle 3PDT, it's your choice regarding what you consider the best for your build.

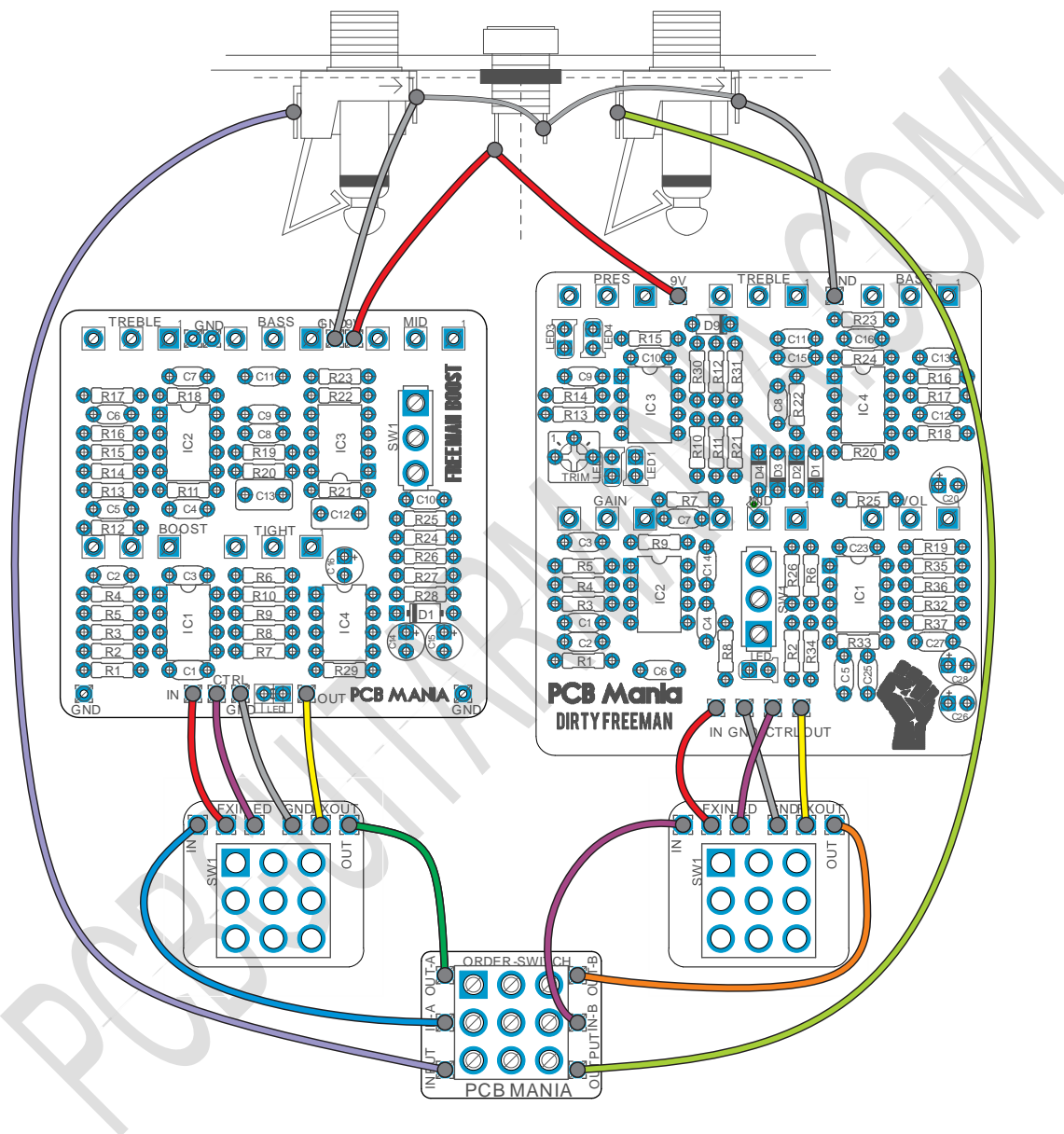

9. Schematics

EZ 3PDT

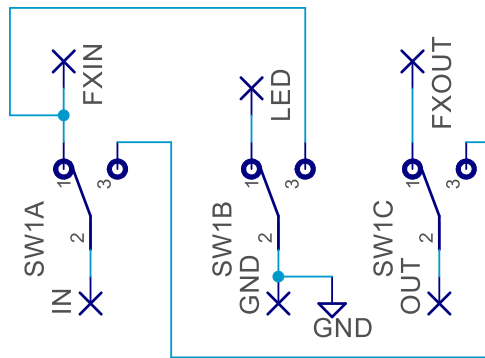

AUX 3PDT

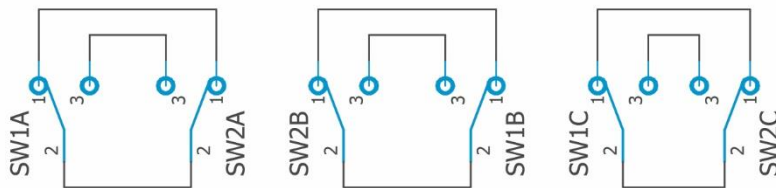

Order Switch

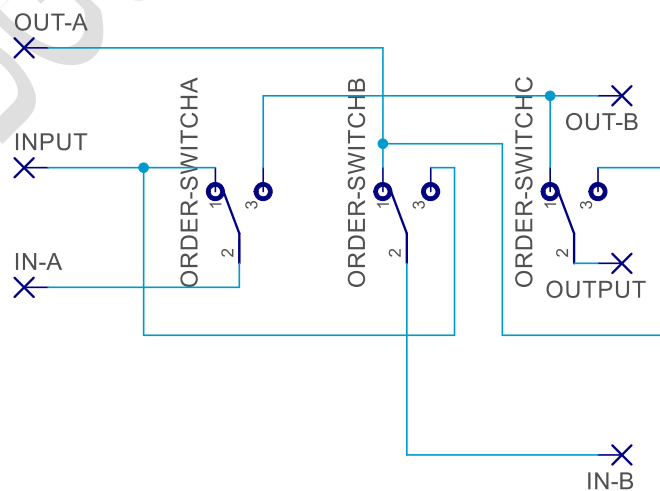

Licensing and Usage

We really appreciate your trust and support buying this PCB, as well as your will to dive into the DIY electronics world. That's why for us is really important that you can make this project work properly and to enjoy not only the building process, but also to experiment and play with it on your rig.

We try to reply to every question we receive on our email or in our social media, but we try to encourage all our customers to join our [PCB Guitar Mania - Builders Group](#) on Facebook, in order to post all your doubts, issues, suggestions or request, as well to share your builds and have some feedback from us and other fellow builders!

All of our projects have been tested following this same guide on their standard configurations. Although, not all of the variations and mods have necessarily been tested. These are suggestions based on the schematic analysis, and on the experiences and opinions of others. Feel free to share with us your opinions and suggestions regarding the mods your own personal experimentation.

These boards may be used for commercial endeavors in any quantity unless specifically noted. No attribution is necessary, though accreditation or a link back is always greatly appreciated.

If you are a builder planning to make your own run of pedals we also offer the service of custom made boards with your brand and logo, design according your specifications.

The only usage restrictions are that, first, you cannot resell the PCB as part of a kit without prior arrangement with us, and second, you cannot scratch off the silk screen, or other way of trying to hide our logos and the source of the PCBs. Like it's written above, if you want to have your own designs, with your brand and logo we could certainly reach an agreement.

Follow us on [Instagram](#) and [Facebook](#) to stay in tune with the latest projects!